

# PROFIMAT MT

Profile grinding  
with increased profitability



## Key data

The PROFIMAT MT – first-class grinding technology for profile grinding.

- 6 machine sizes
- Grinding spindle drive up to 60kW
- Max. wheel speed of 170 m/s

## Blohm Jung GmbH

---

Productivity, performance and precision – three attributes which users worldwide associate with surface and profile grinding machines from BLOHM and JUNG. Our machines have been in use worldwide for decades in widely varying fields of application and under very different conditions. The experience gained from over 35,000 delivered machines is constantly incorporated into further developments and innovations, increasing our customers' production efficiency even further. The product portfolio of Blohm Jung GmbH extends from surface grinding machines through application-oriented universal machines to customer-oriented production machines. Our service and technology specialists support our customers throughout the entire lifecycle of the machine. From grinding tests through training and maintenance contracts to retrofits, we offer our customers prompt and personal advice.

In 2008 the two established brands BLOHM and JUNG merged under one roof. Blohm Jung GmbH has thus combined its extensive know-how and constantly enables new, higher standards in the area of precision, quality and cost efficiency. There are also many opportunities for tailoring production solutions to individual customer requirements.

As part of the UNITED GRINDING Group, Blohm Jung GmbH is represented internationally with offices in India, China, Russia and the USA. A further 40 sales and service agencies guarantee a worldwide presence and customer proximity. The company's main locations are the development and production facility in Hamburg and the service and technology center in Göppingen.

# PROFIMAT MT

The PROFIMAT MT is a robust, high-performance production grinding machine. High speeds and varied applications characterize the PROFIMAT MT. With an extensive range of accessories, the PROFIMAT MT can be optimally adapted to all customer requirements. CD, IPD and all CBN grinding processes are possible on the PROFIMAT MT.

# Characteristics

## Dimensions

- 6 machine sizes with grinding ranges from 400 x 800 mm to 600 x 2,000 mm

## Hardware

- Modular system
- High quality components comprising gray cast iron
- Thermal and vibration engineering characteristics optimized via finite element analysis
- Precision linear guideways
- High quality, recirculating ballscrews

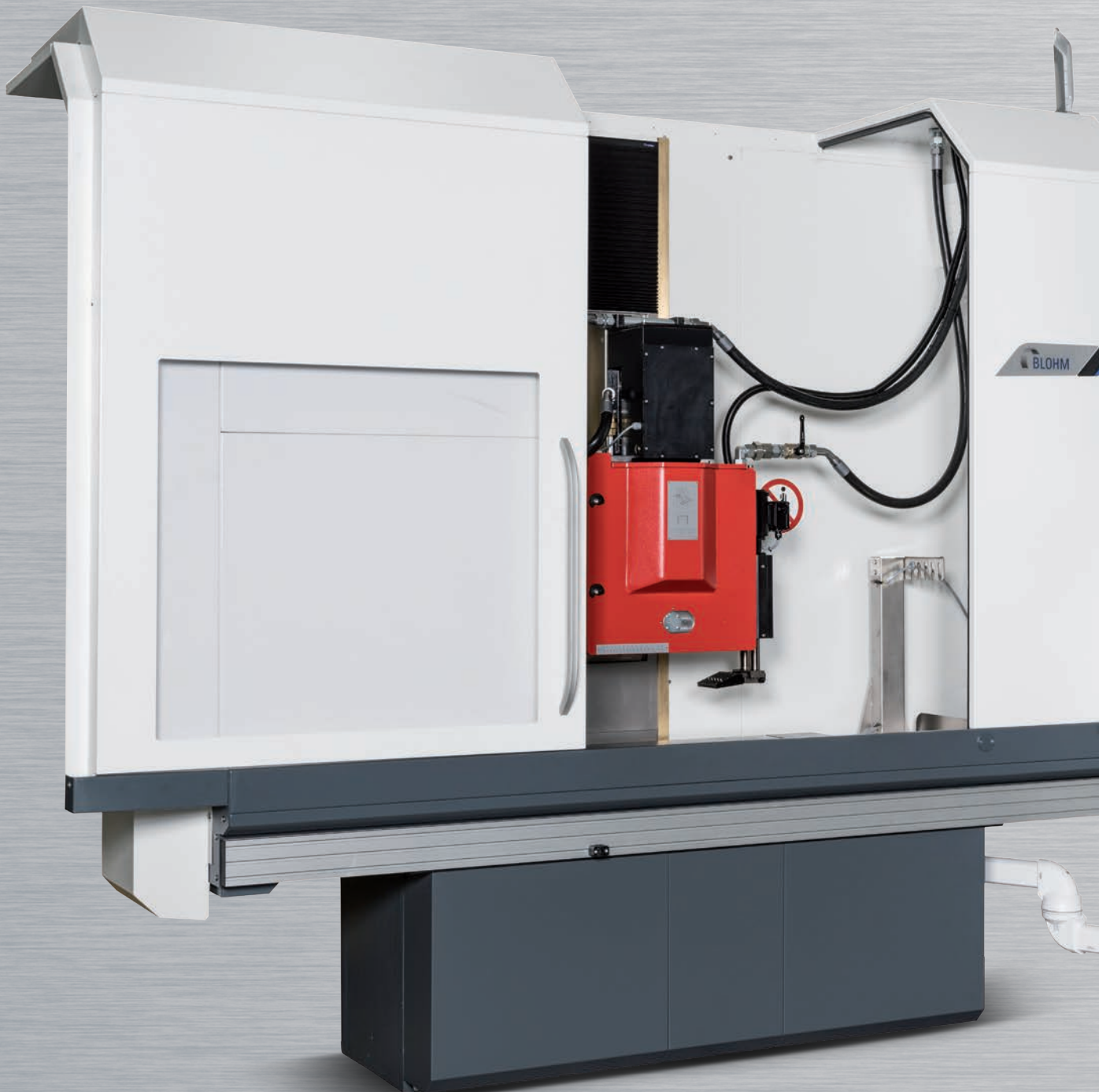

## Software

- Siemens 840D solution line with safety functions
- Optimal operator guidance
- Programming with menu-guided grinding and dressing cycles

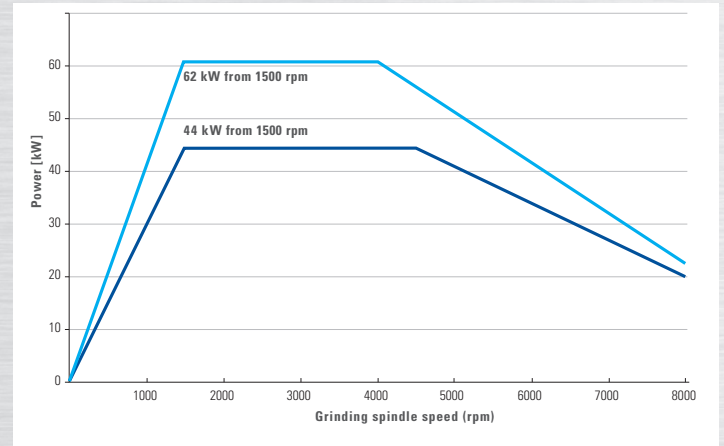

**Grinding spindle** drive power curves

The BLOHM PROFIMAT MT line has been designed purely as a high performance production grinding machine for flexible applied technology. The PROFIMAT MT is the right choice for applications where the production process requires high metal removal rates.

Grinding spindle drives with a power of up to 60 kW and a max. cutting speed of 170 m/s guarantee outstanding performance using conventional, CD or IPD as well as all CBN grinding methods.

Pre-loaded anti-friction guideways in all machine axes guarantee the necessary system rigidity and reduce maintenance requirements. The extremely efficient BLOHM software ensures exact interpolation of the axes and thus high workpiece quality. A large spectrum of standard accessories and special part clamping and part handling systems offer a quick and economic adaptation to customer specific production requirements at high quality.



# Well-proven – the design principle

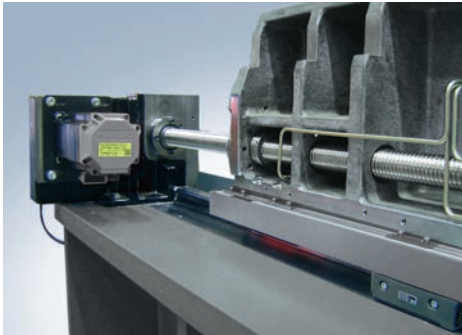
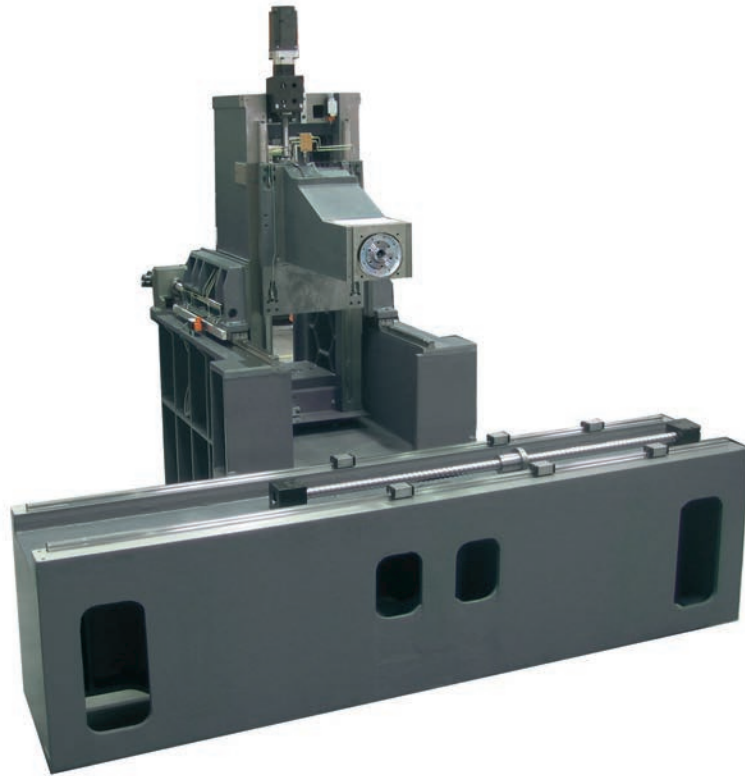

**Z-axis**, with linear glass scale

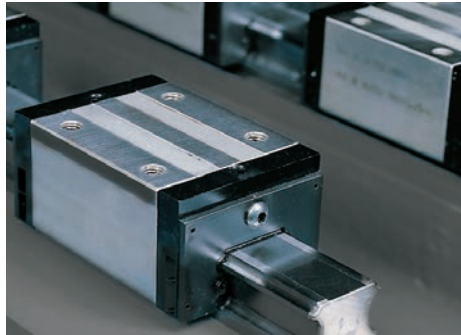

**Precision guideways** for stick-slip free motion

The modular platform concept with high-grade components made of cast iron is thermal and vibration optimized using 3D-CAD and finiteelement analysis.

Selected components guarantee high precision and long life.

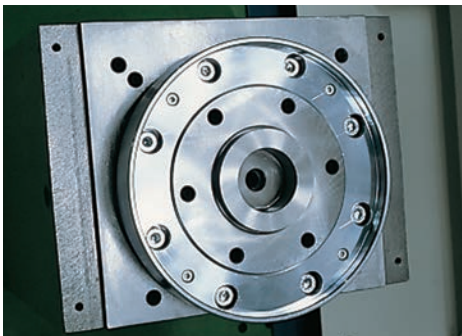

**Cartridge type spindle** with short taper for repeatable grinding wheel positioning



High-grade, ground re-circulating **ballscrews** in all axes for silent operation

# Process optimized accessories



**Vertical auxiliary grinding spindle** for universal use in the mould and die industry with a power of up to 6 kW and up to 90,000 rpm

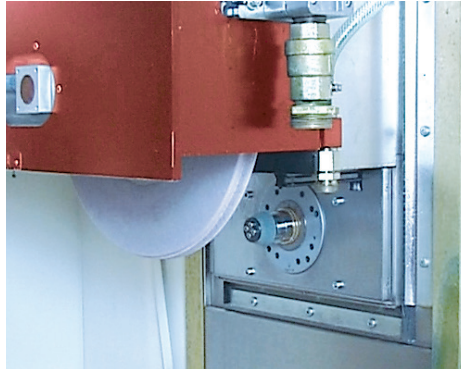

**Horizontal auxiliary grinding spindle,** automatically positioned in the working area, for the back-off grinding on broach tools using a min. wheel diameter of 30 mm



**Measuring probe,** pneumatically retracting from measuring position, up to 2 ½ axes, measuring accuracy +/- 1 µm

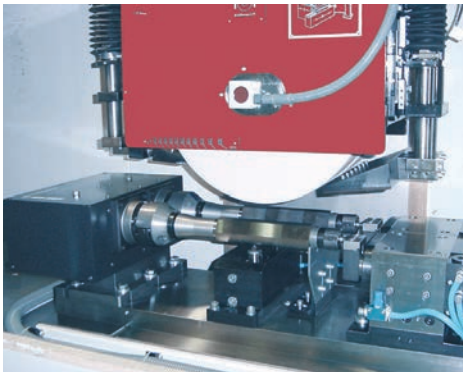

**Twin-spindle NC-indexing table with tailstock,** indexing accuracy +/- 3"

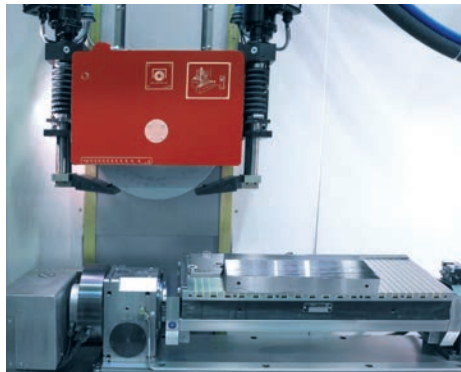

**NC-tilting magnetic chuck,** tilting range +/- 30° indexing accuracy +/- 1"

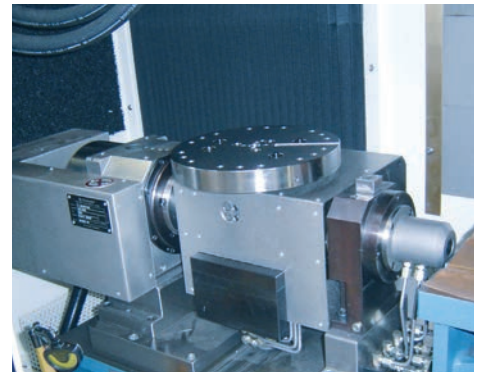

**NC-indexing table,** 1 or 2 axes, indexing accuracy +/- 1"

## Additional available accessories

- Automatic balancing systems
- Coolant filtration units
- Coolant mist exhaust units
- Accessory package for the use of pure grinding oil
- Acoustic sensors

## RazorTec®

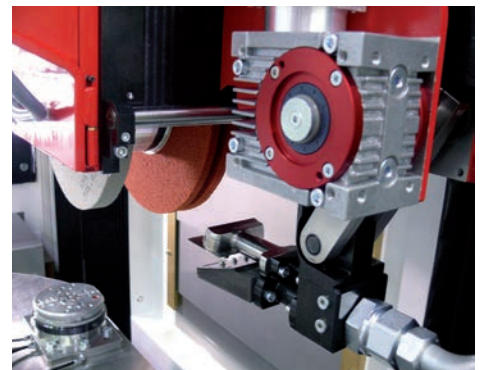

New way of grinding wheel cleaning, with newly developed nozzle positioner, 30% less grinding wheel wear, 30-40 bar nozzle pressure

# CNC Control

The comfortable solution for profile grinding applications



The best machines in a performance class offer more than just technically advanced components. Their high capabilities are made possible by the use of perfectly matched software and technology.

The CNC control Siemens Sinumerik 840D solution line with graphical operator guidance especially developed for grinding applications guarantees an optimal process. The simple programming is supported by menu guided grinding and dressing cycles.

The software option GripsProfile is a comfortable tool, especially for the single piece and batch production, for the automatic generation of grinding and dressing programs.

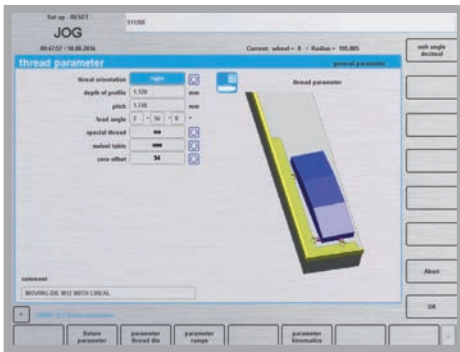

Thread rolling die

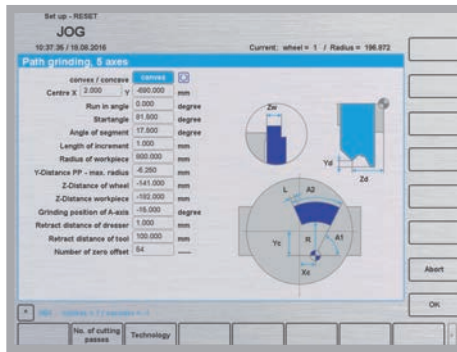

5-axes continuous path controlled grinding

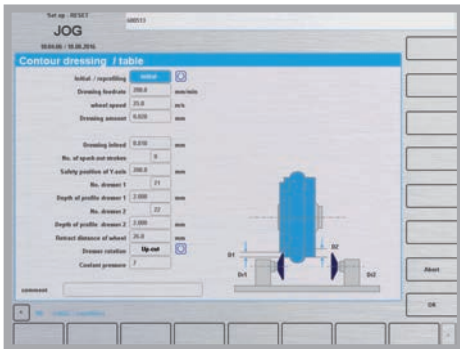

Contour parallel dressing

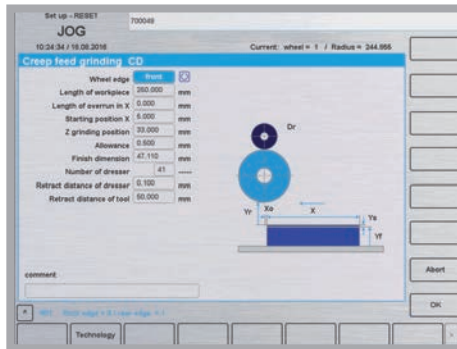

CD-grinding



# Optimal dressing

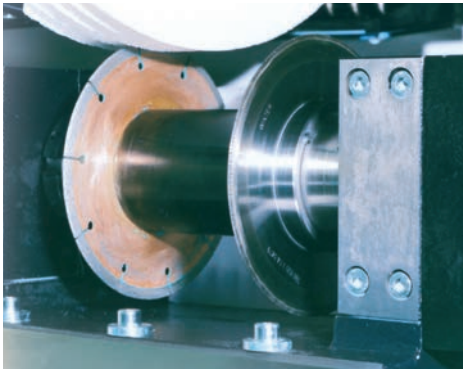

Fast initial profiling using a special roughing tool reduces the cost due to shorter cycles and less wear on precision tools.

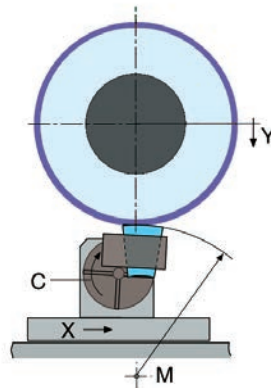

Continuous path controlled grinding, convex/concave, using interpolation of up to 5 axis permits grinding of large radii at utmost accuracy.

**High precision parts are ground using an optimized dressing process offering shortest cycle times and minimal grinding wheel consumption.**

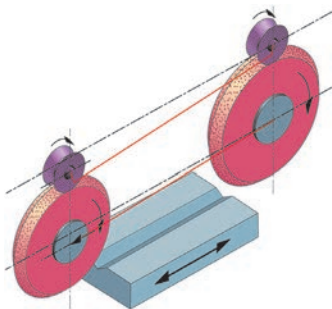

CD-grinding, the grinding wheel is being continuously dressed.

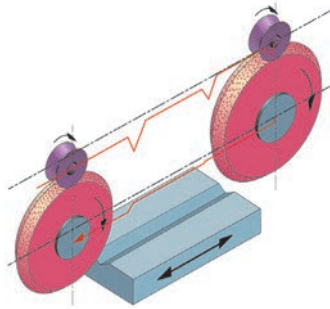

IPD-grinding, the in process dressing whilst grinding saves time and the possible grinding length is extended by the optimized grinding wheel topography.

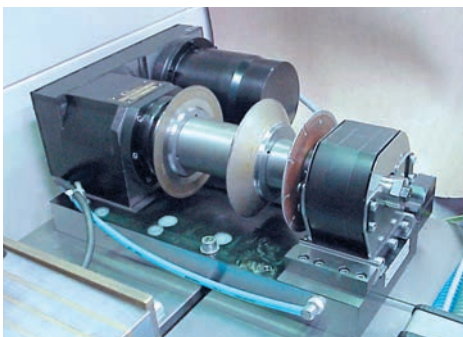
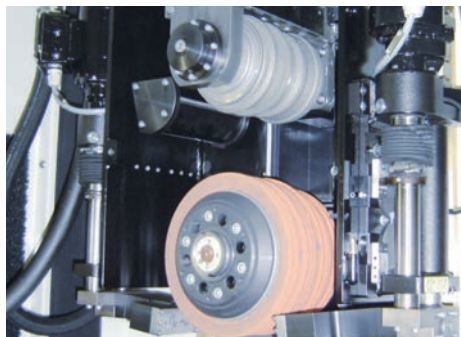

Table mounted dresser type PEA-TR200S for diamond rolls up to a width of 200 mm or for contour dressing with universal diamond dressing disks and a rough dressing disk.



Overhead dressing system PEA-K for IPD and CD grinding methods designed for a grinding wheel width of up to 200 mm.

# BLOHM Solutions

Automotive industry and suppliers

---

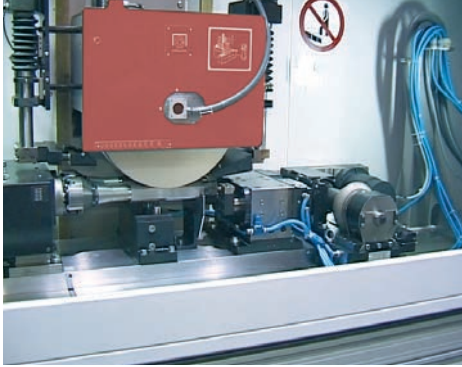

Roller for diesel injection pump

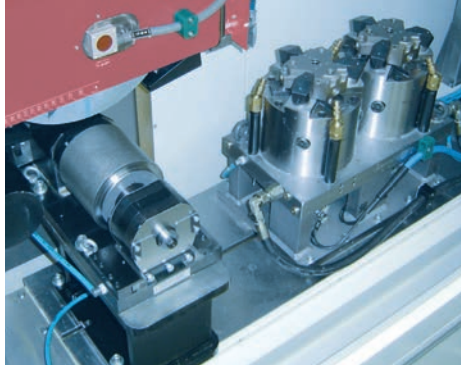

Housing for diesel injection pumps

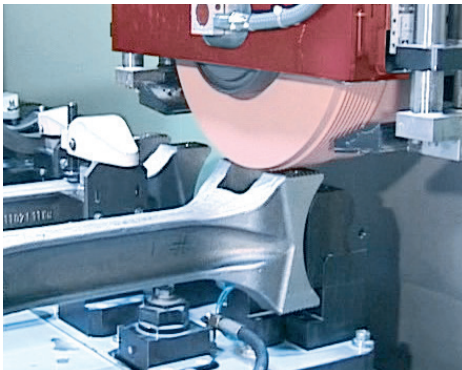
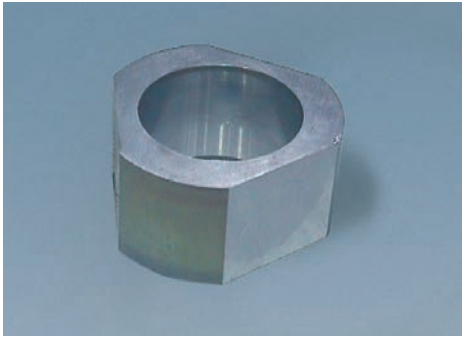

Connecting rod and cap



Steering racks

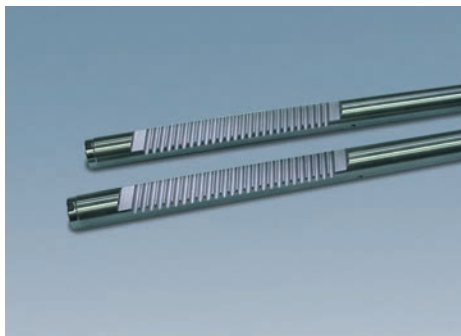

## Turbine industry

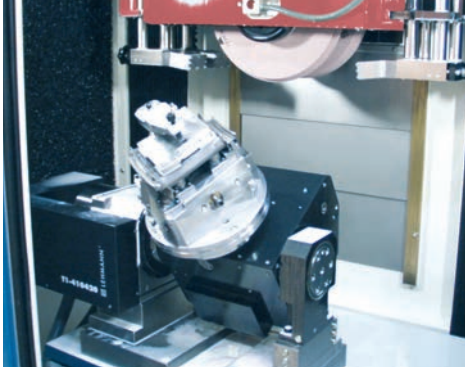

Turbine vane – 5 axes continuous path controlled grinding

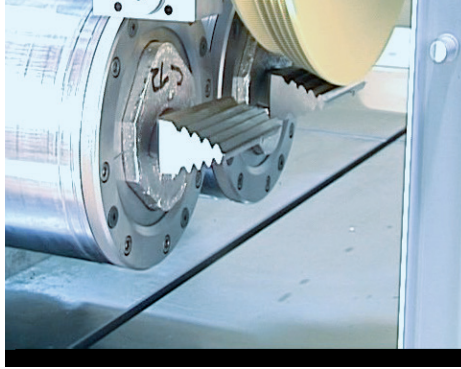

Turbine blade

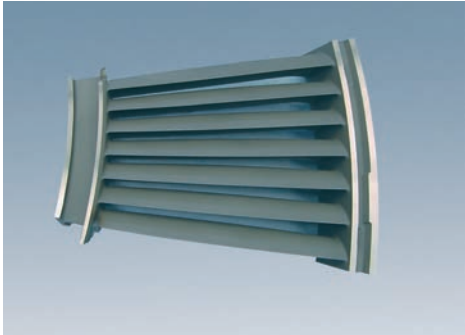

Root profile

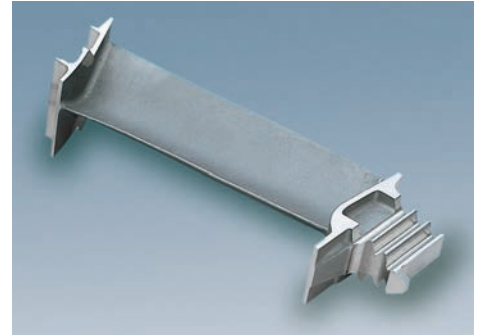

Root and shroud profile



Compressor blade – multiple operations in one set-up

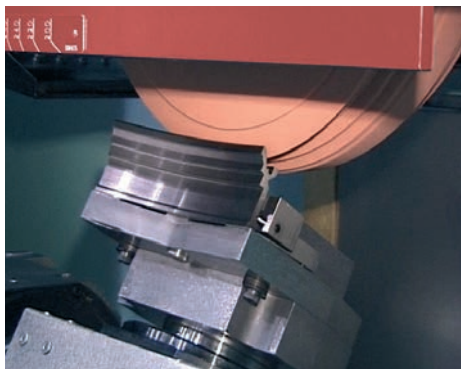

Shroud segment – multiple operations in 1 set-up

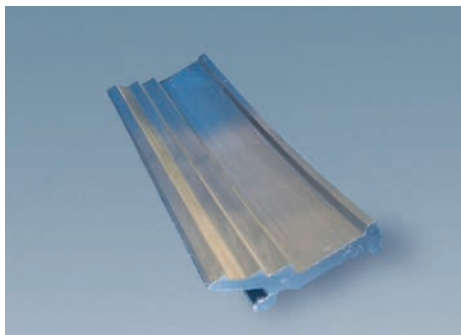

# BLOHM Solutions

Tool and die industry

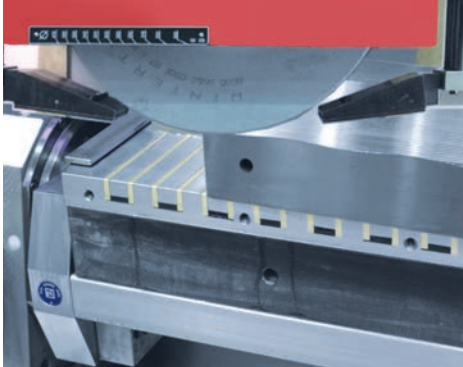

Thread rolling die

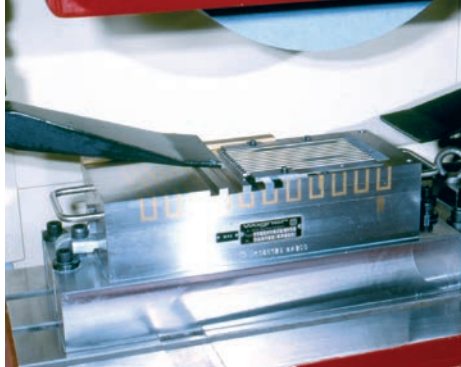

Ejector

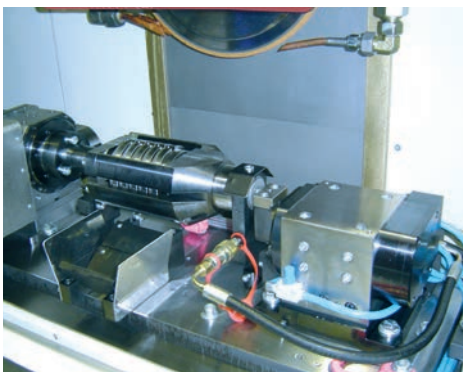
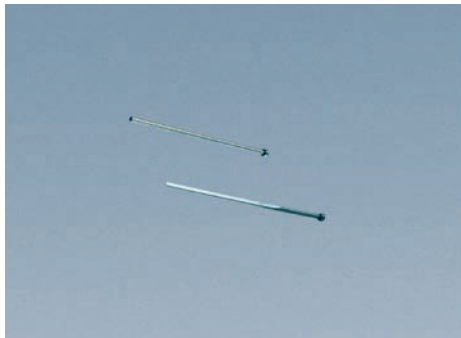
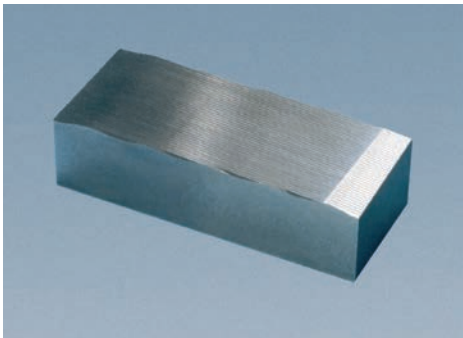

Die

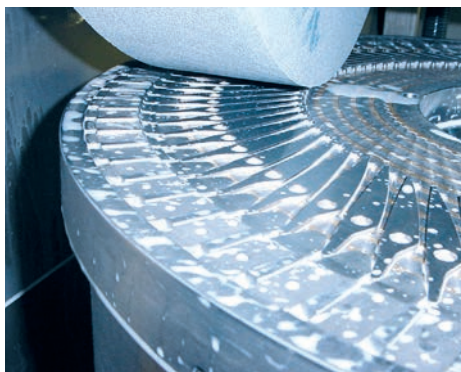

Scissors

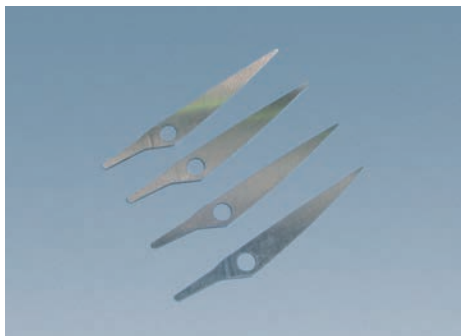
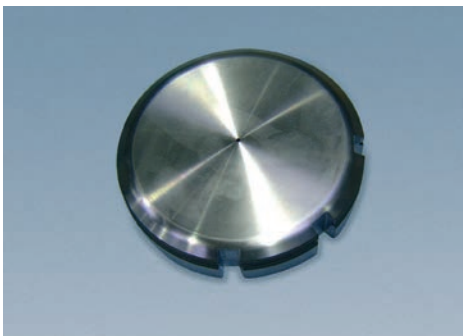

## Machine building

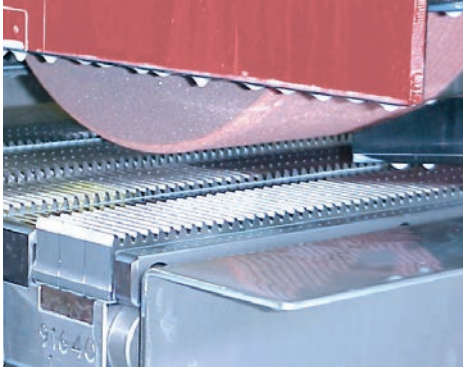

Tooth rack



Chuck jaw

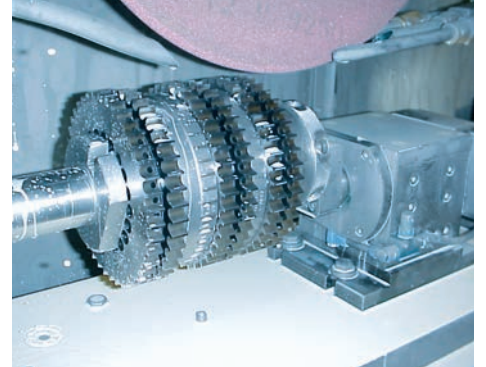

Transfer drum

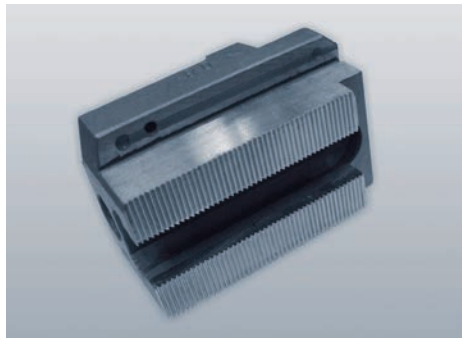

Rail

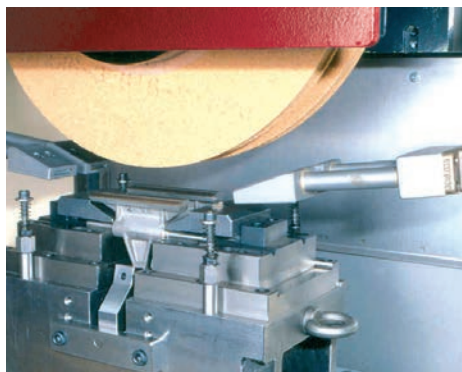

Lever

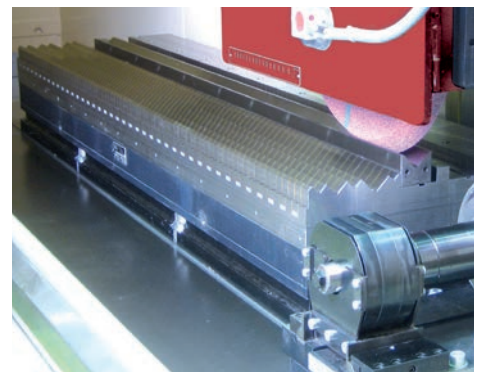

Guideway

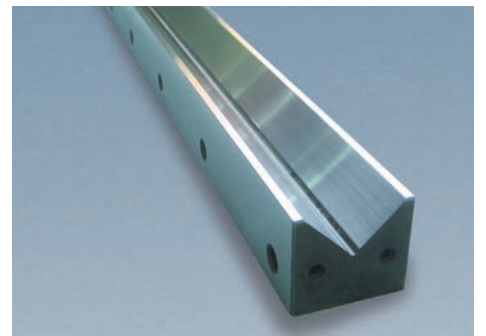
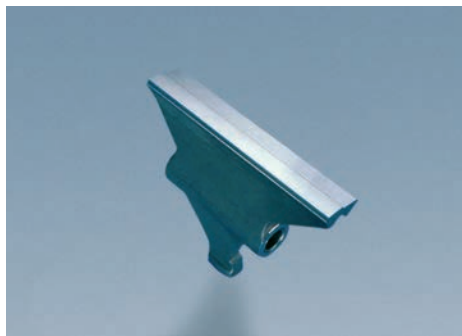
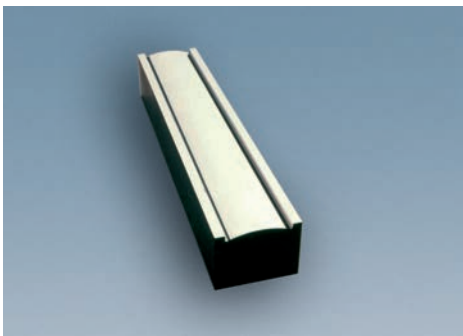

# Customer Care

BLOHM and JUNG surface and profile grinding machines should fulfill the customer's requirements for as long as possible, work cost-effectively, function reliably and be available at all times. From "start up" through to "retrofit" – our Customer Care is there for you throughout the working life of your machine. 6 professional helplines and more than 25 service technicians are available in your area, wherever you are in the world.

- We will provide you with fast, uncomplicated support.
- We will help to increase your productivity.
- We work professionally, reliably and transparently.
- We will provide a professional solution to your problems.



**Start up**  
Commissioning  
Warranty extension



**Qualification**  
Training  
Production support



**Prevention**  
Maintenance  
Inspection



**Service**  
Customer service  
Customer consultation  
HelpLine  
Remote service

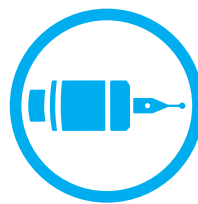

**Material**  
Spare parts  
Replacement parts  
Accessories



**Rebuilt**  
Machine overhaul  
Assembly overhaul



**Retrofit**  
Modifications  
Retrofits  
Machine trade-in

# Technical data

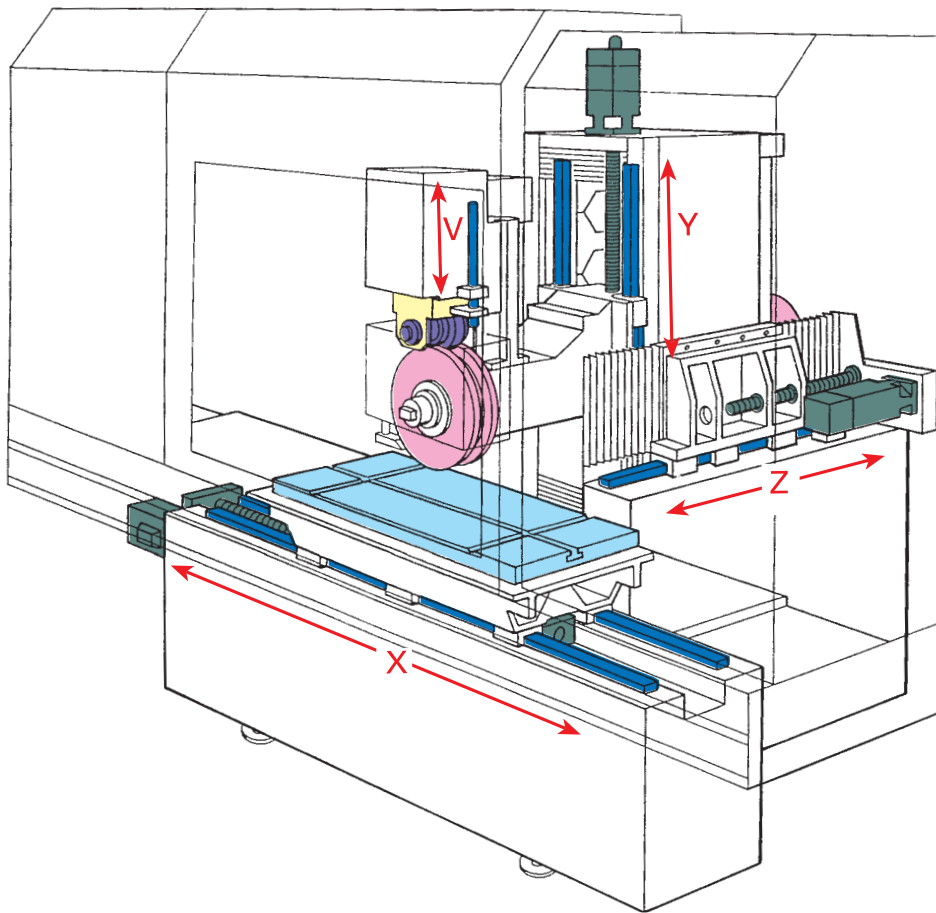

PROFIMAT MT		408	412	608	612	616	620
Grinding Range	mm	400 x 800	400 x 1,200	600 x 800	600 x 1,200	600 x 1,600	600 x 2,000
Table clamping area with auxiliary surface	mm	400 x 1,200	400 x 1,600	600 x 1,200	600 x 1,600	600 x 2,000	600 x 2,400
Distance table to spindle center	mm	150 ... 700 (optional 950)					
X-axis, machine table longitudinal travel, max.	mm	900	1,300	900	1,300	1,700	2,100
Feed rate	mm/min	15 ... 25,000					
Y-axis, wheel head vertical travel	mm	550 (optional 800)					
Feed rate	mm/min	4 ... 3,750					
Z-axis, column cross travel	mm	320	320	520	520	520	520
Feed rate	mm/min	4 ... 4,000					
V-axis, stroke of overhead dresser (opt.)	mm	130					
Grinding spindle drive, variable speed, AC motor	kW/rpm	up to 60/8,000					
Grinding wheel size (d x w x bore)	mm	up to 500 x 200 x 127 (203.2)					
Dimensions Width	mm	3,500	4,500	3,500	4,500	5,600	5,900
Depth <sup>1)</sup>	mm	4,500	4,500	4,700	4,600	4,600	4,700
Height	mm	2,700 <sup>2)</sup>	2,700 <sup>2)</sup>	2,700 <sup>2)</sup>	2,700 <sup>2)</sup>	2,700 <sup>2)</sup>	2,700 <sup>2)</sup>
Machine weight, without electrical cabinets	kg	6,500	6,700	7,500	8,000	8,000	8,000

<sup>1)</sup> incl. electrical cabinets and operator panel

<sup>2)</sup> 3,400 with enrised column



Blohm Jung GmbH

**Location Hamburg**

Kurt-A.-Körper-Chaussee 63-71  
21033 Hamburg  
Phone +49 40 33461 2000  
Fax +49 40 33461 2001  
sales-hh@blohmjung.com

**Location Göppingen**

Jahnstraße 80-82  
73037 Göppingen  
Phone +49 7161 612 0  
Fax +49 7161 612 170  
sales-gp@blohmjung.com

[www.blohmjung.com](http://www.blohmjung.com)

