

FlexGrind

Universal cylindrical grinding



Key data

The FlexGrind is the ideal universal cylindrical grinding machine for machining large, heavy workpieces in the high-precision range. With a distance between centers of 2 to 4 meters and nine headstock variants, many different customer applications can be implemented. The integrated DIATRONIC absolute measuring head makes the FlexGrind unique in this machine class.

Schautd Mikrosa GmbH

Schautd Mikrosa GmbH is synonymous worldwide for premium technology in cylindrical, noncircular, and universal grinding between centers, as well as in centerless external cylindrical grinding. Since 2009, the company combines the two long-established brands SCHAUDT and MIKROSA in a modern factory in Leipzig.

Our special strength lies in the high customer-individuality of our machines and the connection of units, automation components and process engineering to a highly productive grinding system.

Here, SCHAUDT is the brand for the automotive industry and its suppliers. It offers sophisticated technological solutions for cylindrical, noncircular and eccentric grinding. Our highly experienced experts also have unparalleled expertise in the high-precision grinding of long and heavy workpieces like rollers and turbine shafts. Within this broad application range, you obtain everything from a single source – application development, technology, assembly, and sales.

MIKROSA sets the standards in centerless external cylindrical grinding of rotationally symmetrical parts. The modular machine design means that you obtain a solution with handling and automation individually tailored to your grinding task. The technology spectrum extends from precision infeed grinding in many different variations to super productive throughfeed grinding. This allows you to machine a very large variety of workpieces, from small jet needles through to large shafts.

Schautd Mikrosa GmbH is part of the UNITED GRINDING group, one of the leading suppliers of machines, applications, and services for hard-fine machining worldwide. The group comprises eight strong brands with own subsidiaries and sales partners around the world to be a strong partner for our customers.

FlexGrind

Highest precision for large, heavy workpieces · 9 wheel-head variants · Modular design · Gauged grinding with DIATRONIC absolute measuring head · User-friendly WOP-G/X programming system

Features

Dimension

- Grinding length 2,000/3,000/4,000 mm
- Height of centers 260/310/355 mm
- Max. grinding wheel dimension 900 x 300 mm
- Max. workpiece weight 500/1,200 kg

Hardware

- Machine bed with welded steel construction
- Table slide machine
- 9 wheelhead variants
- Backlash-free workpiece drive
- High-precision B-axis with swivel angle of -45° to $+225^{\circ}$
- Scraped vee-flat guideway in the Z-axis
- Bridge type steady rest
- DIATRONIC absolute measuring head



Software

- Service-friendly SIEMENS SINUMERIK 840D sl control system
- Proven WOP-G/X programming software for grinding cylindrical and noncircular workpiece contours with user-oriented set-up interface
- Standardized interfaces for loader and peripheral devices



Thanks to its modular design, the FlexGrind is the ideal universal cylindrical grinding machine for the high-precision production of long and heavy workpieces. It machines workpieces from 2,000 to 4,000 mm in length, with different heights of centers and a weight of up to 500/1,200 kg, depending on the version.

A variety of grinding operations, such as external and internal cylindrical grinding, cylindrical and noncircular grinding, thread grinding and traverse grinding, are available for the complete machining of different workpiece geometries. With nine standard headstock variants a wide variety of applications are possible for machine tools and vehicle manufacture. The workpiece range for machining extends from rollers, shafts and spindles for machine tools through engine parts and railway axles to pressure cylinders, web guide rollers and gearbox components for wind power plants and pumps.

SCHAUDT developed the WOP-G/X Windows-based operator interface on the basis of the SIEMENS SINUMERIK 840D control system. It is characterized by maximum user friendliness and enables set-up and changeover without any special programming knowledge. The entire sensor technology such as DIATRONIC, sparking and balancing is integrated into the operator interface. The DIATRONIC absolute measuring head makes the FlexGrind unique in this machine class. It enables in-process gauging for different diameters during grinding. The measuring head thus controls the grinding process. Programming is exceptionally simple. Simply select «Grinding with measuring head» in the cycle and enter the relative position of the measuring head to the grinding wheel. Mechanical truing processes are not required.

Machine bed

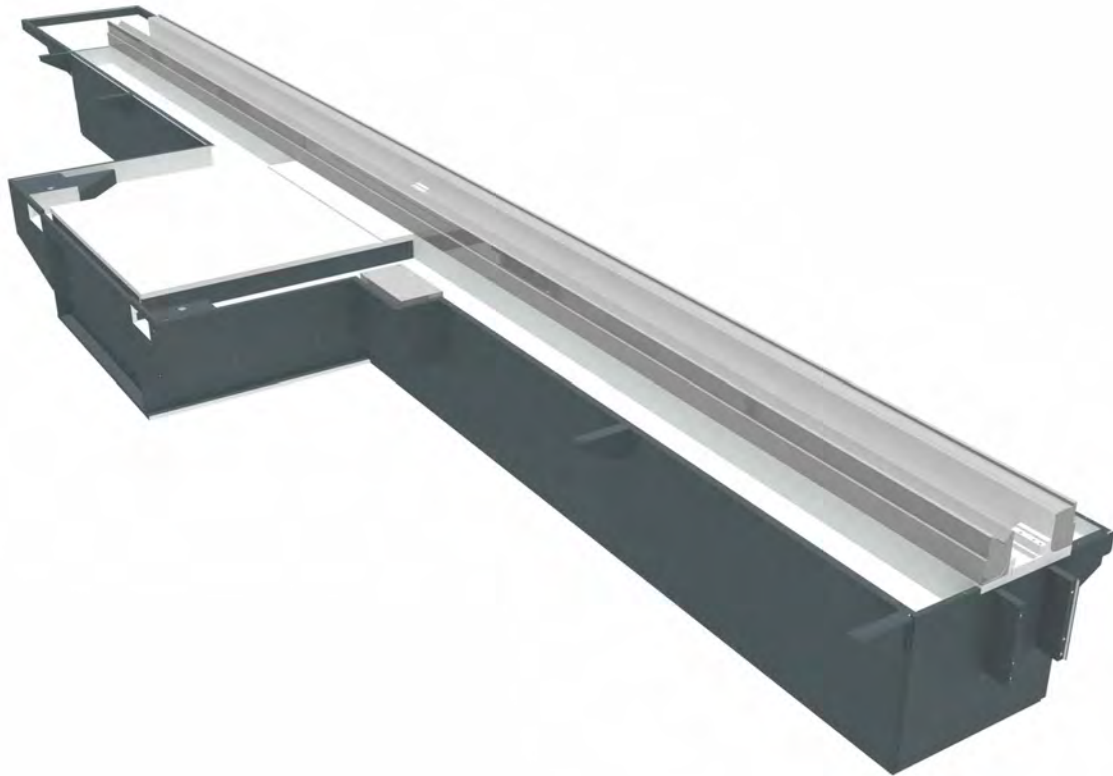

Your advantages

- Table slide design
- High rigidity
- Lower weight

The FlexGrind has a machine bed with a welded steel construction, featuring a table design with impressively high rigidity. The moving axes are deliberately separated. The tank system and integration of bed and assembly cooling units enable temperature stability to be achieved within the machine.

The machine bed with its welded steel is especially suitable for large machines, as it weighs much less than a purely or partially mineral cast bed.

Wheelhead

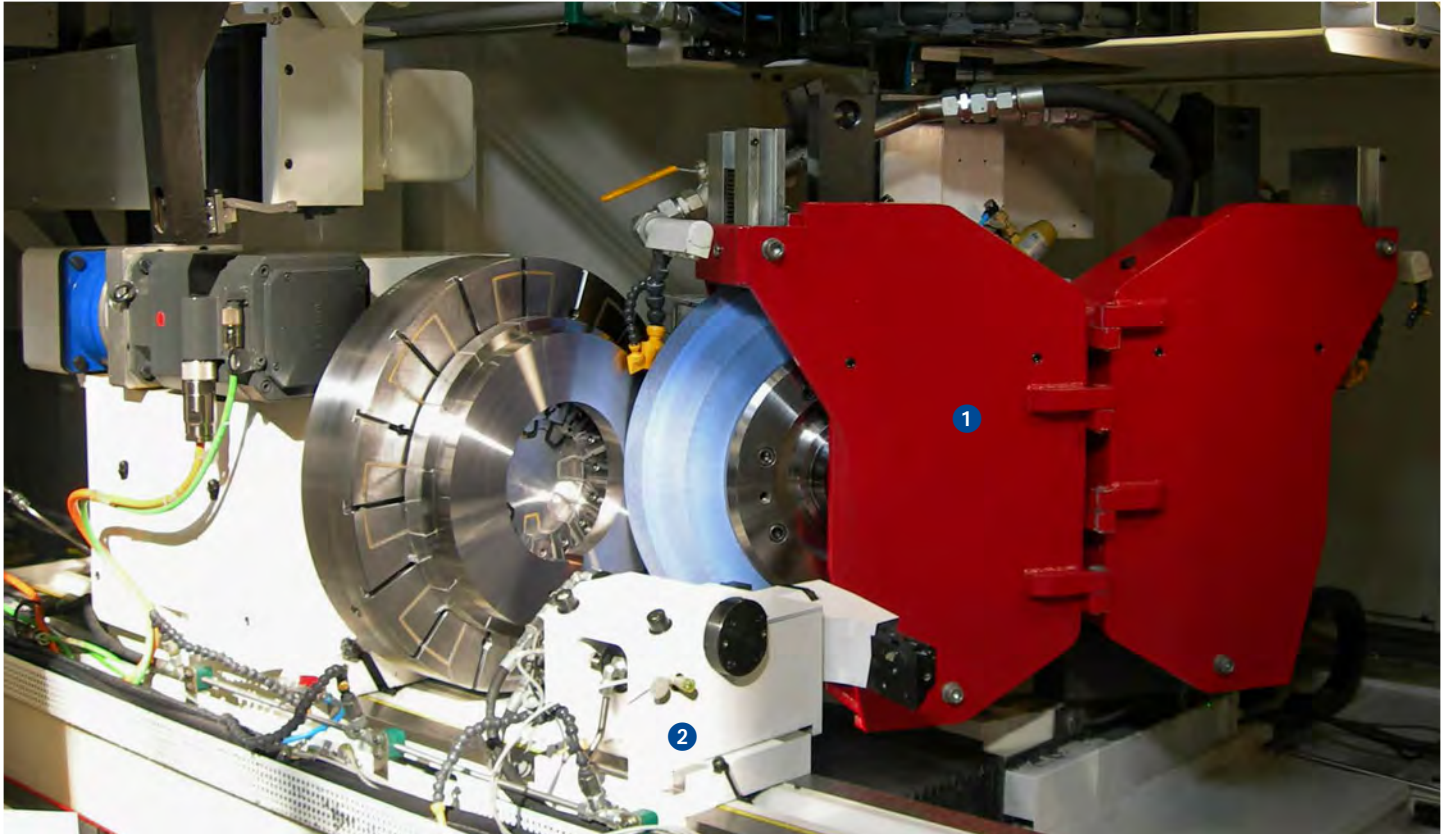

Your advantages

- Table slide design
- High rigidity
- Lower weight

9 standard headstock variants are available for the FlexGrind series. This enables the performance of a wide variety of grinding operations such as external and internal cylindrical grinding or thread grinding. The external grinding spindle is designed as a motor spindle mounted on roller bearings. Different motor spindles are available for internal grinding.

The digitally controlled, high-precision B-axis has a swiveling range of 270°. The integrated absolute measuring system guarantees a repeatability precision of $\pm 0.5''$.



- ① B-axis
- ② Swiveling dresser for internal grinding

- ③ Internal grinding spindle
- ④ External grinding spindle

Workhead

1

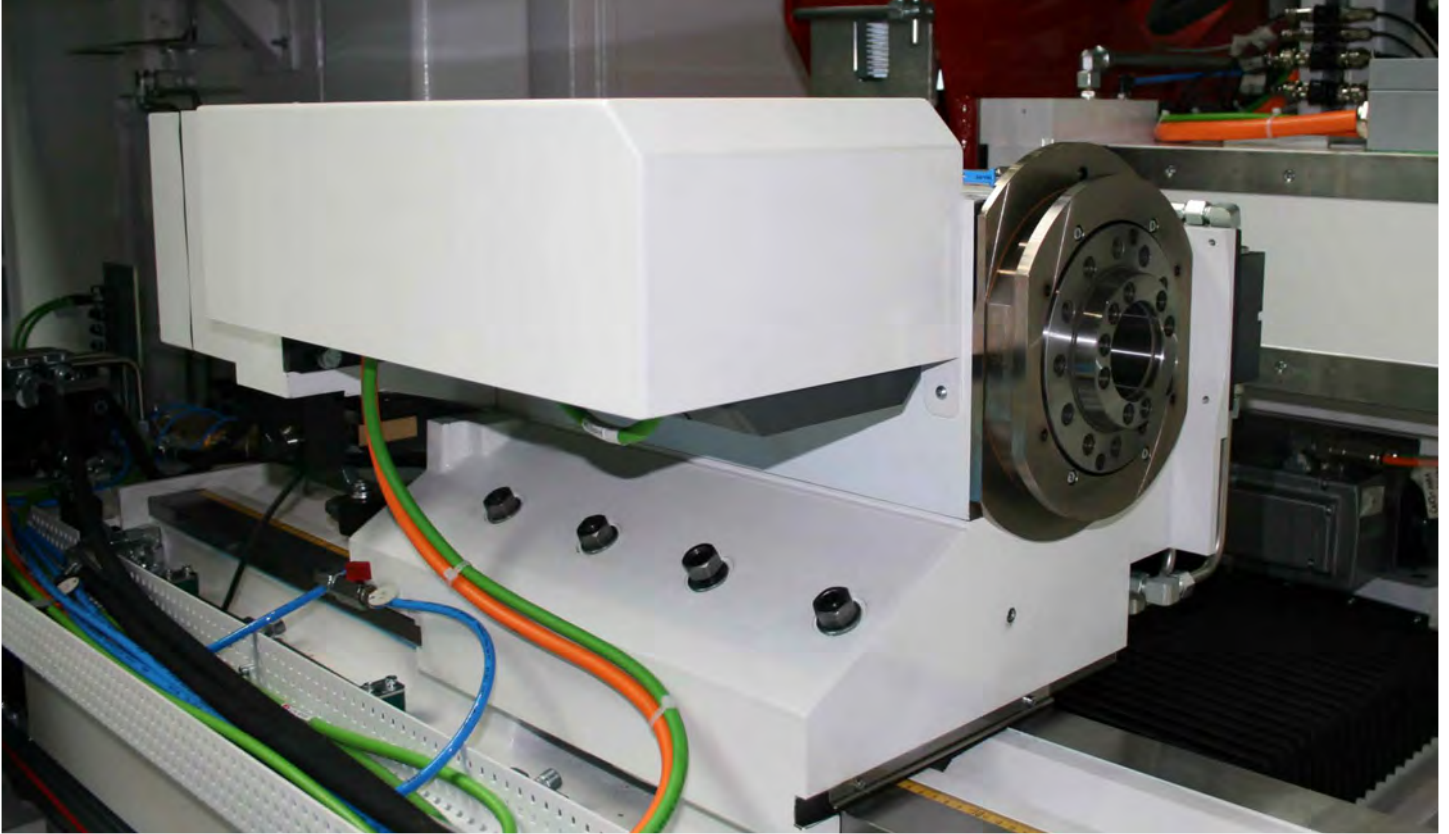

Your advantages

- Excellent runout characteristics
- High rigidity
- Very high torque
- High dynamics

The FlexGrind features a high-precision, belt-driven workhead, which possesses excellent runout characteristics. The headstock is distinguished by an outstanding torque curve in C-axis mode.

Two further workheads are available in addition to the standard version. The machine can thus be configured for noncircular grinding of very heavy workpieces or for the highest dynamics using direct drive, for example on polygons or eccentrics.

2



3

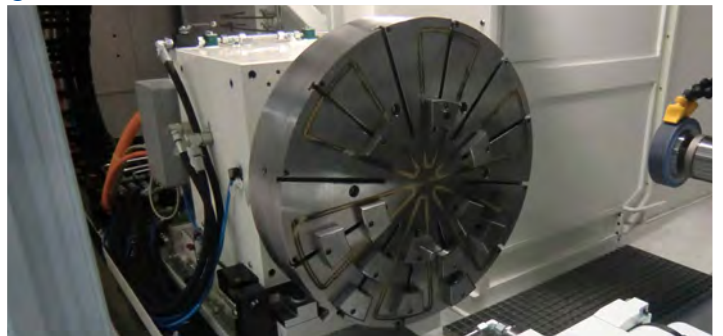

1 Standard workhead

2 Workhead for noncircular grinding of heavy workpieces

3 Workhead with direct drive

Tailstock

1



Your advantages

- Great versatility
- Suitable for heavy workpieces

Two barrel tailstocks with plain-bearing guides are available for the FlexGrind. The small variant with fixed center point has a stroke of 100 mm and is suitable for workpieces up to 500 kg. The barrel adjustment occurs hydraulically, while the clamping force is adjusted by means of variable spring assemblies, which can also be pretensioned manually, workpiece-dependently.

The large tailstock has a stroke of 150 mm and is suitable for workpieces up to 1,200 kg. It is equipped with a rotating barrel, which can be locked if required. The clamping force is generated hydraulically.

Also, supporting steady rests are available for the machine. This increases the possible workpiece weight to up to 2,500 kg.

2

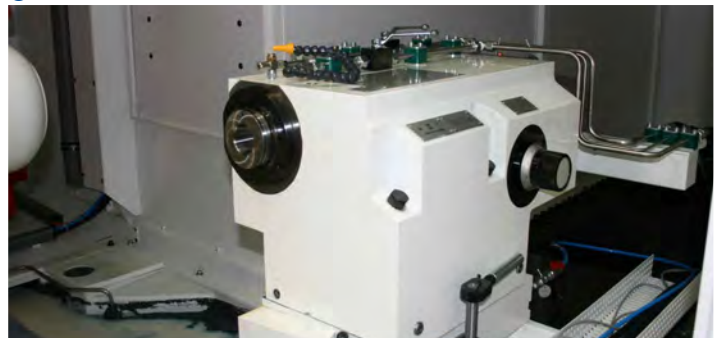

3

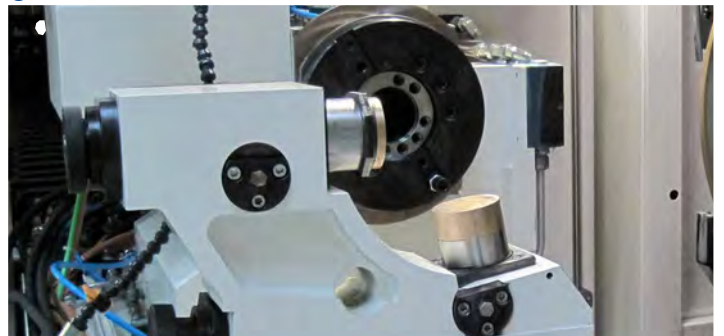

DIATRONIC

1

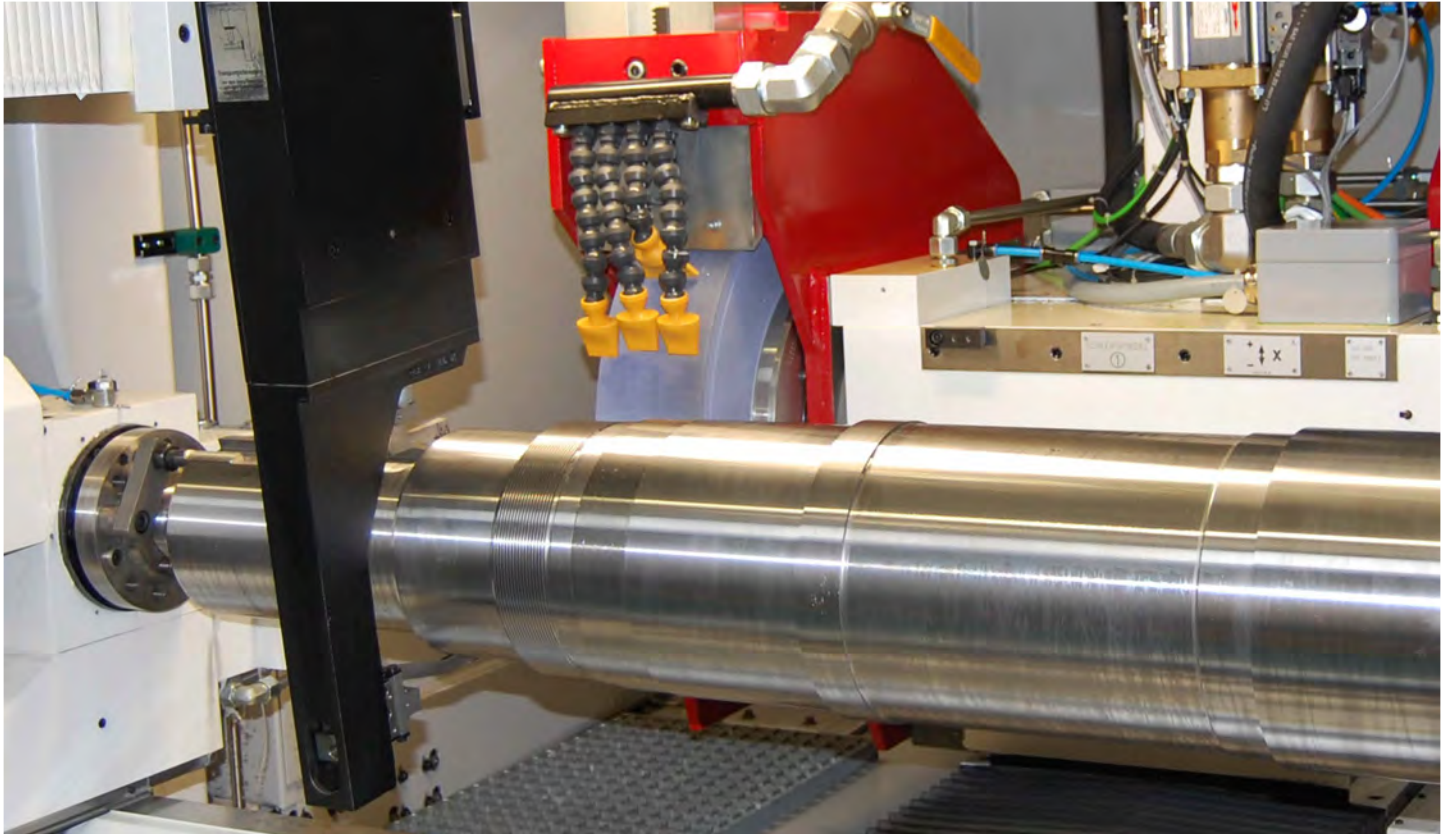

Your advantages

- Higher accuracies
- Direct measurement during the process at the grinding positions (depending on the spindle grinding angle)
- Automatic operation possible without manual corrections
- Compensation of error sources such as variations in temperature

The FlexGrind is equipped with the DIATRONIC 22 diameter and length measuring system. This absolute measuring head significantly increases flexibility and quality assurance during automatic machining. The measurement of different diameters during the grinding process is unique for this machine class. The measuring range extends for 160 or 200 mm/Ø across the entire grinding length. The measuring head thus controls the grinding process.

Programming is exceptionally simple, as the DIATRONIC measuring system is integrated directly into the operator interface. The high-precision production of large, heavy workpieces is thus possible on the FlexGrind, as any thermal, static and dynamic influences are corrected during grinding.

Bridge type steady rest

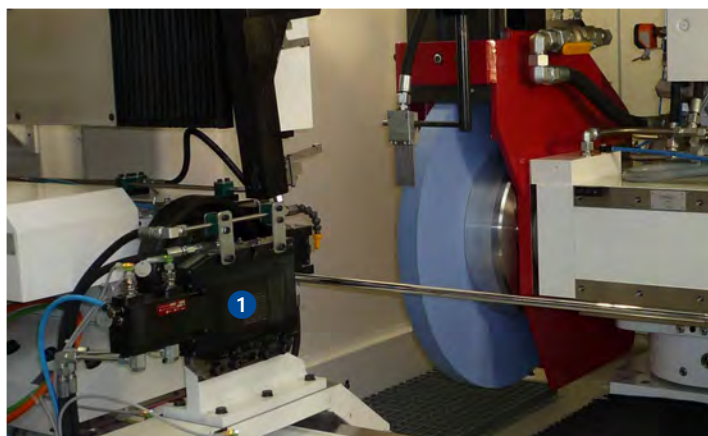

The FlexGrind can optionally be equipped with a bridge type steady rest. As a result only one steady rest is required for machining long, slender workpieces. This guarantees a constant rigidity across the entire workpiece length during the grinding process. The unit costs are significantly reduced thanks to the short set-up times. At the same time the highest accuracies are achieved.

Your advantages

- Only one steady rest required
- Constant rigidity for long, slender workpieces
- Low investment costs

Internal grinding

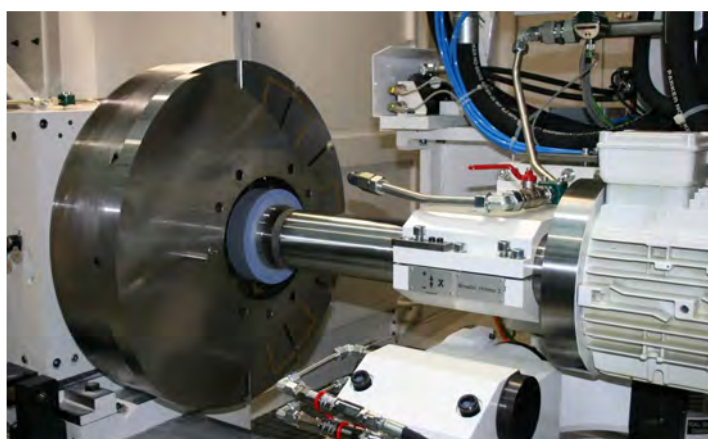

The FlexGrind is a combined external and internal grinding machine for machining large, heavy workpieces in a single clamping. The machine's productivity is substantially increased due to the reduced set-up time.

Your advantages

- External and internal grinding in one machine
- Highest precision
- Reduced set-up time

Peel grinding



Flexible grinding process allows machining times to be reduced by up to 45%. The unit costs are substantially reduced even for large parts as a result. Thanks to the low process forces very thin-walled workpieces can be machined. Convex or concave generating lines are no problem during peel grinding.

Your advantages

- Reduced machining time
- Grinding of thin-walled workpieces
- Convex or concave generating lines

WOP-G/X programming interface

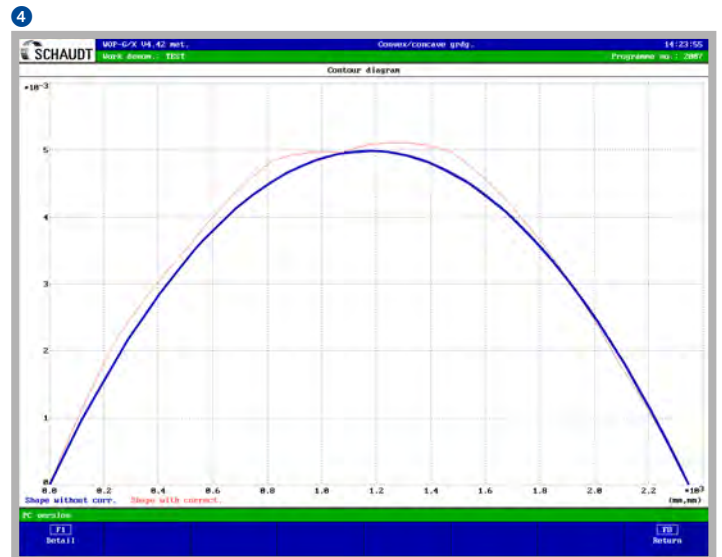
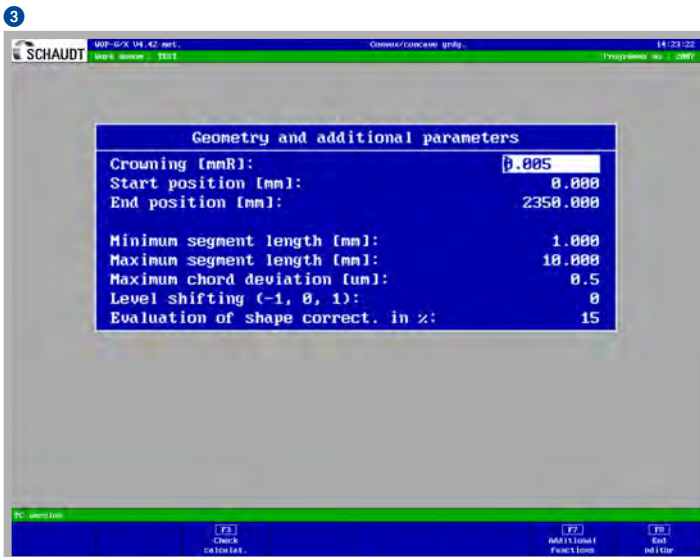

Your advantages

- User-friendly
- Easy creation of grinding programs
- Wide functional scope

Programming cylindrical and noncircular workpiece contours is quick and easy with the WOP-G/X programming system from SCHAUDT. WOP-G/X creates harmonic speed profiles, which can be variably adapted, from just a few inputs. This enables combination machining of concave and convex profiles in a single clamping with the highest precision. The contour data are read in via a data table. No special formatting is required. The input profiles are stored in a database and can be called up again at any time.

A shape analysis of the contour can be performed in respect of concavity and relevant maximum values, based on the read-in table.

The WOP-G/X programming software can also be used on another external computer, creating an additional external programming station. If the machine also has network access, a common data pool can be accessed via both the control system and the external programming station.

Customer Care

SCHAUDT grinding machines should fulfill the customer's requirements for as long as possible, work cost-effectively, function reliably and be available at all times. From "start up" through to "retrofit" – our Customer Care is there for you throughout the working life of your machine. 12 professional helplines and more than 60 service technicians are available in your area, wherever you are in the world.

- We will provide you with fast, uncomplicated support.
- We will help to increase your productivity.
- We work professionally, reliably and transparently.
- We will provide a professional solution to your problems.



Start up

Commissioning
Warranty extension



Qualification

Training
Production support



Prevention

Maintenance
Inspection



Service

Customer service
Customer consultation
HelpLine
Remote service

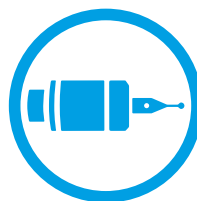

Material

Spare parts
Replacement parts
Accessories



Rebuild

Machine overhaul
Assembly overhaul



Retrofit

Modifications
Retrofits

Technical data

FlexGrind M

Grinding range

Grinding length, max.	mm	2,000/3,000/4,000
Height of centers	mm	260/310/355
Workpiece weight	kg	500/1,200

Wheelhead

B-axis	-45°-225°
--------	-----------

Grinding wheels

Diameter, max.	mm	600/750/900
Width, max.	mm	125/200/300
Peripheral speed	m/s	63
Driving power	kW	30

Workhead

Rpm range of spindle / rotational axis	rpm	1...100/300/1,000
Torque at spindle / rotational axis	Nm	55/145/600
Torque at spindle / rotational axis		MK6 / flange head
Spindle nose moment, max.	Nm	3,000

Tailstock

Tailstock type	barrels	
Stroke, max.	mm	150
Center point mounting	MK6 / flange head	

Dimensions

Overall area (including control cabinet)	mm	2,770 x 6,740 to 2,770 x 11,840
Height, max.	mm	3,000
Machine weight	t	9-15

Available headstock variants

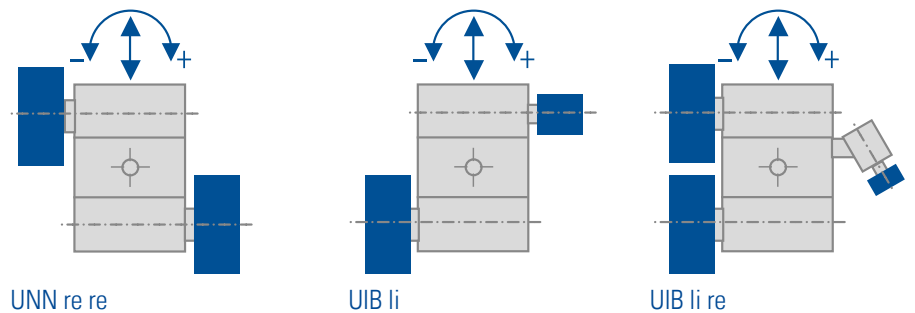
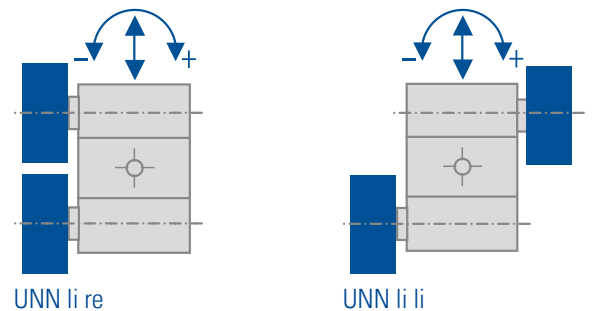
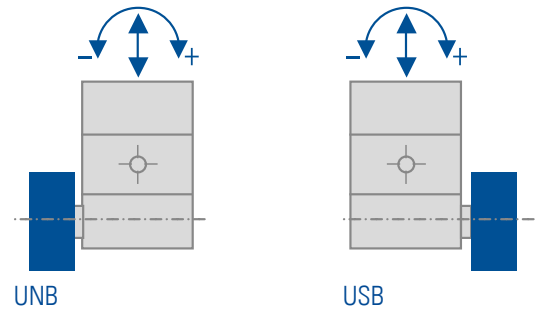
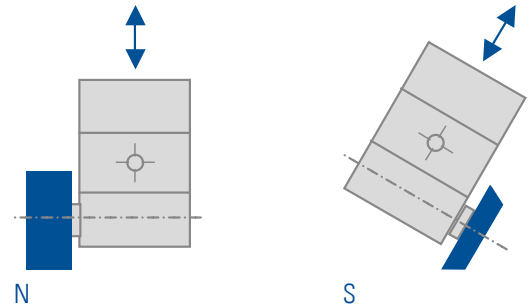

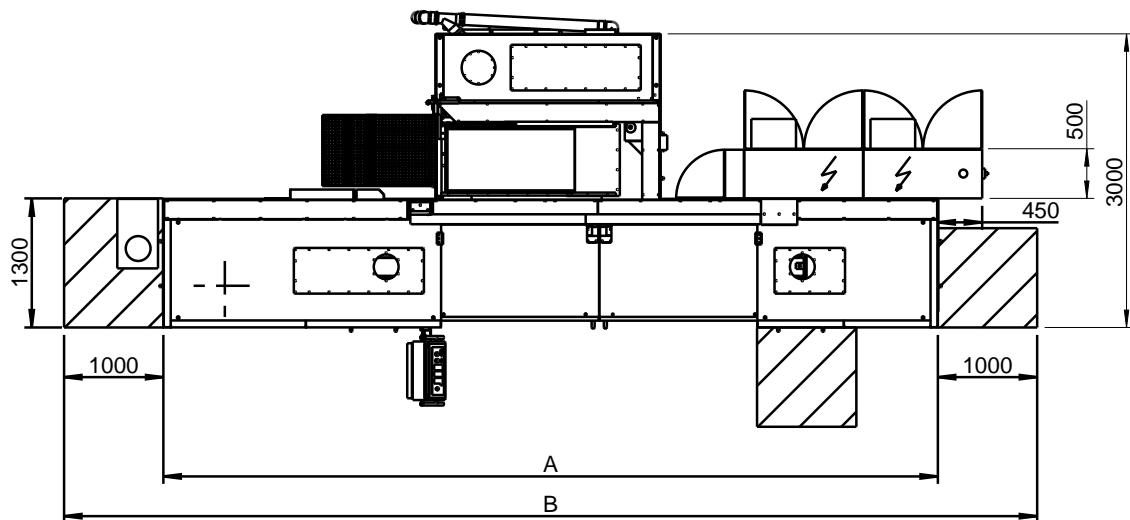
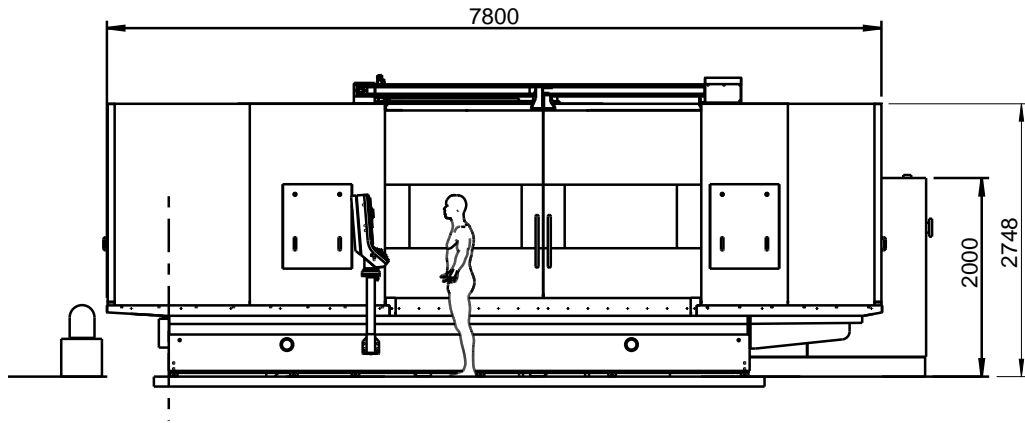

Layout FlexGrind M 2000

Basic measurements:

FlexGrind M 3000	9,800 mm
FlexGrind M 4000	12,000 mm



Schaudt Mikrosa GmbH
Saarländer Straße 25
04179 Leipzig
Germany
Tel. +49 341 4971 0
Fax +49 341 4971 500
sales@schaudtmikrosa.com
www.schaudt.com

