

# favorit

UNIVERSAL CYLINDRICAL GRINDING MACHINE





## APPLICATIONS

## STUDER favorit IN USE

This CNC universal cylindrical grinding machine is designed for grinding short to long workpieces in individual and batch production. Thanks to various options such as a measuring system, balancing system, contact detection, and longitudinal positioning, you can increase the efficiency of this machine even further.



## favorit

### DIMENSIONS

- Distance between centers 400 / 650 / 1000 / 1600 mm (15.7"/25.6"/39.4"/63")
- Center height 175 mm (6.9")
- Max. workpiece weight 150 kg (330 lbs)

### HARDWARE

- Selectable wheelhead:
  - Universal wheelhead with grinding wheel right or left and an internal grinding attachment. Automatic swiveling with 3° Hirth serration
  - External wheelhead with grinding wheel left, 0°, or right, 0°/15°/30°
- External and internal grinding possible in one setup
- Granitan® S103 mineral-cast machine base

### SOFTWARE

- Very simple programming thanks to StuderPictogramming
- StuderWIN programming software (optional) for creating grinding and dressing programs on an external PC

## YOUR BENEFIT

- Short machining time thanks to complete machining
- Can optionally be equipped with a loader interface (loader provided by customer)
- Maximum precision due to perfect interplay between hardware and software
- Intuitive, user-friendly, and efficient operation
- Environmentally friendly thanks to targeted measures to reduce energy consumption
- Ergonomic thanks to large sliding doors and three service doors

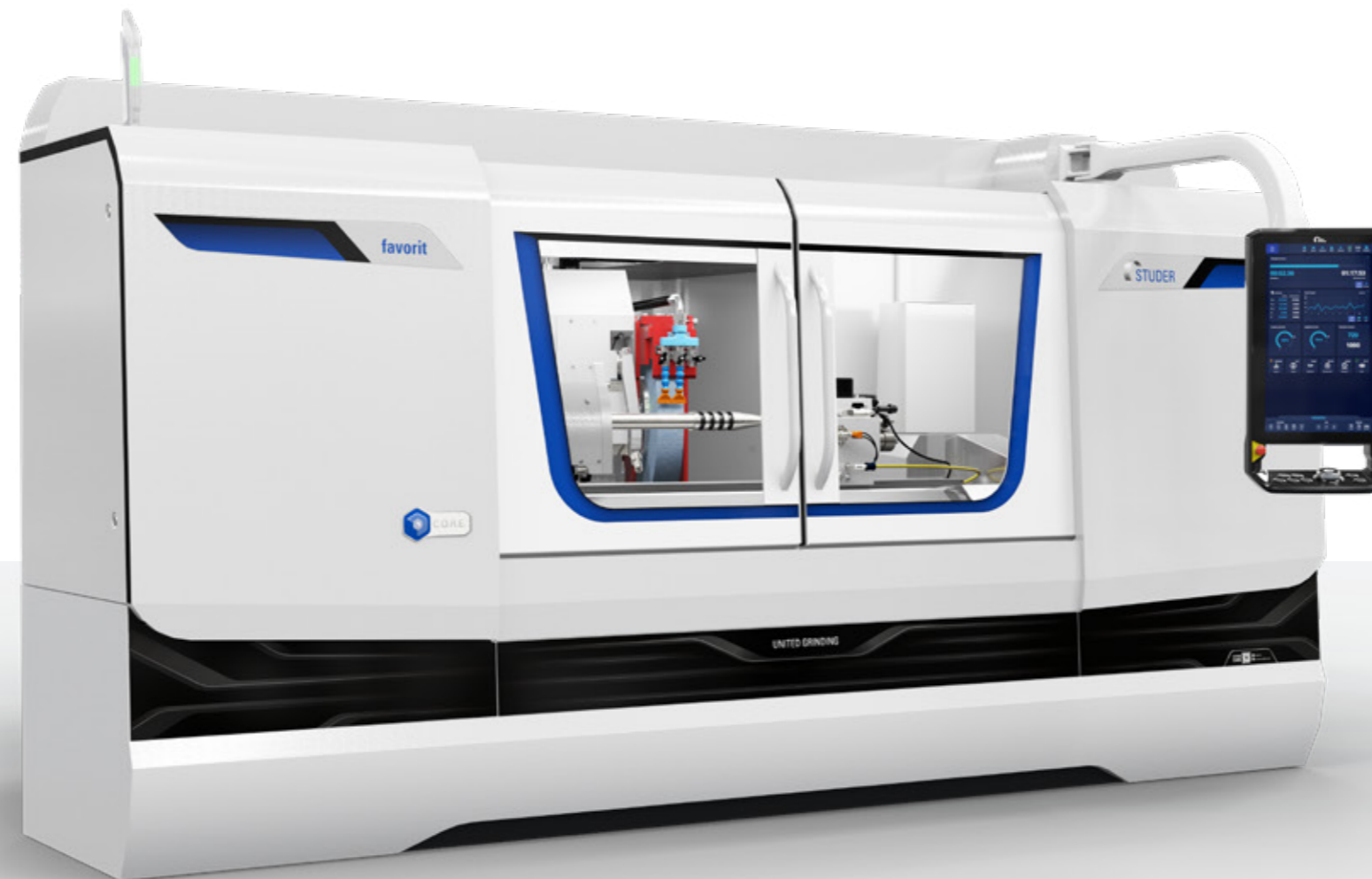

«The price hit for a large range of applications.»

# C.O.R.E. – CUSTOMER ORIENTED REVOLUTION

## C.O.R.E. helps us make your production fit for the digital future.

It's based on a new operating system, C.O.R.E. OS that equips the machine with intelligence.

Thanks to the uniform C.O.R.E. software architecture, exchanging data between UNITED GRINDING machines is easy. The integrated umati API can be used to communicate with third-party systems as well. It also offers access to UNITED GRINDING Digital Solutions™ products directly on the machine. C.O.R.E. not only establishes the technical foundation for this and other IoT and data applications, it also forms the basis of revolutionary yet uniform operation.

### What does this mean for you?

- The user-friendly, intuitive, and uniform operation makes work easier for machine setters, machine operators, and maintenance staff
- Standardized data collection and intelligent processing of data creates transparency and supports process optimization
- The uncomplicated and consistent use of modern digital software solutions is guaranteed – directly on the machine
- The technical platform for the use of modern IoT and data applications has been established

# C.O.R.E. ELEMENTS

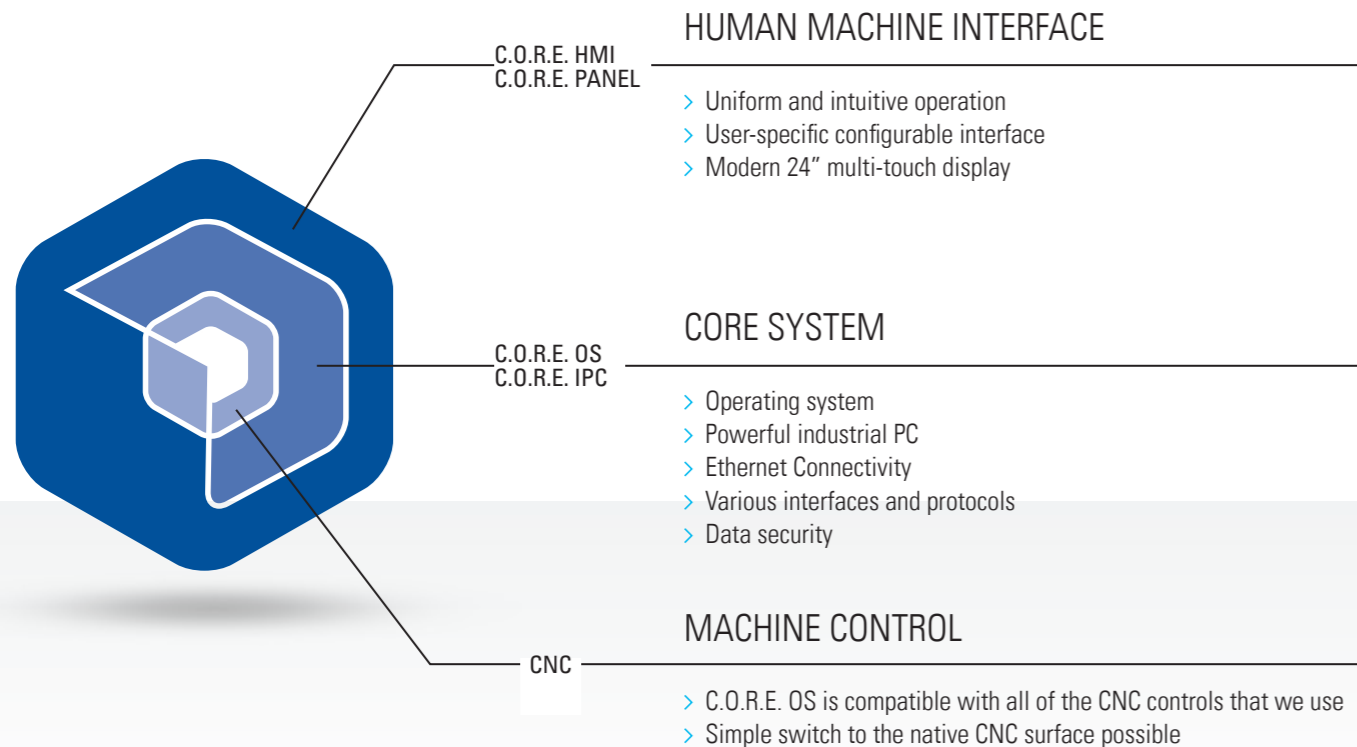

# C.O.R.E. PANEL – THE FUTURE OF OPERATION

## Intuitive

Thanks to intuitive design with self-explanatory icons, navigation through the machine menu and process steps is quick and easy. Instead of buttons, the user is presented with a modern and clearly arranged multi-touch display.

## User-friendly

Each user configures their own user interface individually. This is called up automatically with the RFID chip after logging in. When the user leaves the machine, the panel switches to «Dark Factory Mode.» Production progress and the machine state are also clearly visible from a

distance. And thanks to the ergonomic design, the panel can be tilted and individually adjusted easily.

## Efficient

The uniform and intuitive operating philosophy reduces training time. The configurable and role-specific interface helps prevent errors and increases the efficiency and quality of programming. Information can be exchanged quickly and in real-time via the front camera and Bluetooth headset. UNITED GRINDING Digital Solutions™ products can be used directly on the panel.

INDUSTRIAL MULTI-TOUCH DISPLAY

INTEGRATED FRONT CAMERA

SELF-EXPLANATORY ICONS

USER-CONFIGURABLE DISPLAY

STANDARDIZED FUNCTION KEYS

ERGONOMIC OVERRIDE SWITCH



### Technical Specifications

- 24" Full HD multi-touch display
- 16-position rotary override switch
- Electronic key switch (RFID)
- Integrated front camera
- 2x USB 3.0 ports
- Adjustable tilt

## USER INTERFACE StuderWIN

The user interface StuderWIN creates a stable programming environment and contributes to the efficient use of the machine. The possibility of fully integrating the measuring system and sensor technology for process control, contact detection and balancing systems in the operator interface enables standardized programming of the different systems. The software of an optional loading system is also integrated. The drive elements are optimally matched to the control system.

The sophisticated mechanical engineering concept of the S33 is completed by a grinding software program, developed in-house by STUDER and which is continuously being optimized in cooperation with users. This software offers:

- **StuderPictogramming:** The operator strings the individual grinding cycles together – the control unit generates the ISO code.
- **STUDER QuickSet:** The software for measuring the grinding wheel reduces changeover times by up to 90%.
- **Microfunctions:** Free programming of grinding and dressing process sequences for optimization of the grinding process.
- **Integrated operating instructions** assist safe machine operation.

- The software options for the grinding technology calculations, optimized dressing as well as the Contour, Thread-, and Formgrinding cycles increase the functionality of the machine.

### StuderTechnology – More than 110 years of know-how

StuderTechnology Integrated drastically simplifies the operation of cylindrical grinding machines. Component quality, machining time, energy efficiency – in other words: all important production factors – bring enormous benefits. What makes the software unique? Its history! Over 110 years of grinding experience have gone into it. It is a combination of grinding practice, empiricism, and years of expert knowledge. The program contains data from countless grinding tests, where the best processing strategy was determined case-by-case for a wide range of components. StuderTechnology Integrated reverts specifically to these values depending on the case. The integrated grinding knowledge can be further optimized as required by the individual grinding experts and stored as a customer-specific production specification. This also enables operators with little experience to benefit from STUDER expertise.

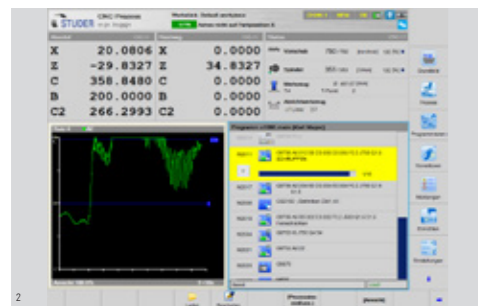
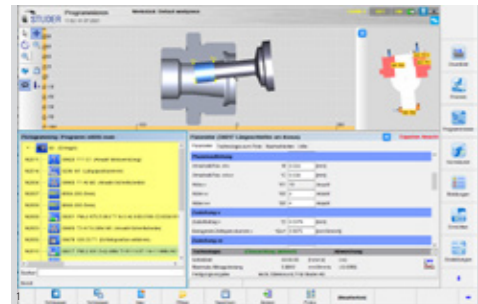

1 Programming interface with StuderPictogramming  
2 Process screen  
3 External programming station

### Integrated Tools

The functionality of STUDER grinding machines can be significantly increased through numerous enhancement packages. STUDER offers the required software packages in the form of integrated tools.

- **StuderDress Integrated** reduces the profiling time of a grinding wheel by up to 80%.
- **StuderThread Integrated**, together with the STUDER thread grinding cycles, offers the full functionality that is otherwise only possible with a special thread grinding machine.
- **StuderContourBasic Integrated** is ideal for traversing geometry contours with the grinding wheel in an easy, quick, and safe manner.
- **StuderContourPRO Integrated** generates the complete grinding program for complex external geometries, typically for peel grinding from solid material.
- **StuderForm Integrated** is the universal out-of-round grinding software for machining curves and polygons for standard applications in low volume production.

### LaserControl™

Non-contact measurement directly on the machine when machining precision workpieces. Not only can “uninterrupted” workpiece diameters of various sizes be measured with the laser measuring device, but also precise control measurements without contact on “interrupted” diameters, such as shafts with keyways or longitudinal grooves, tool cutting edges, guide rails, and gear teeth diameters. The STUDER software logs the measured values after each measuring cycle.

### TouchControl™

Workpieces are inspected directly on the machine, the results are logged and corrections are transferred to the control system.

- Flexible diameter and length control measurement by means of a touch probe
- Seat-specific and tool-specific calculation of dimensional deviations
- Logging of post-process control data
- Programmable cycle for automatic calibration of the touch probe to the reference diameter or length

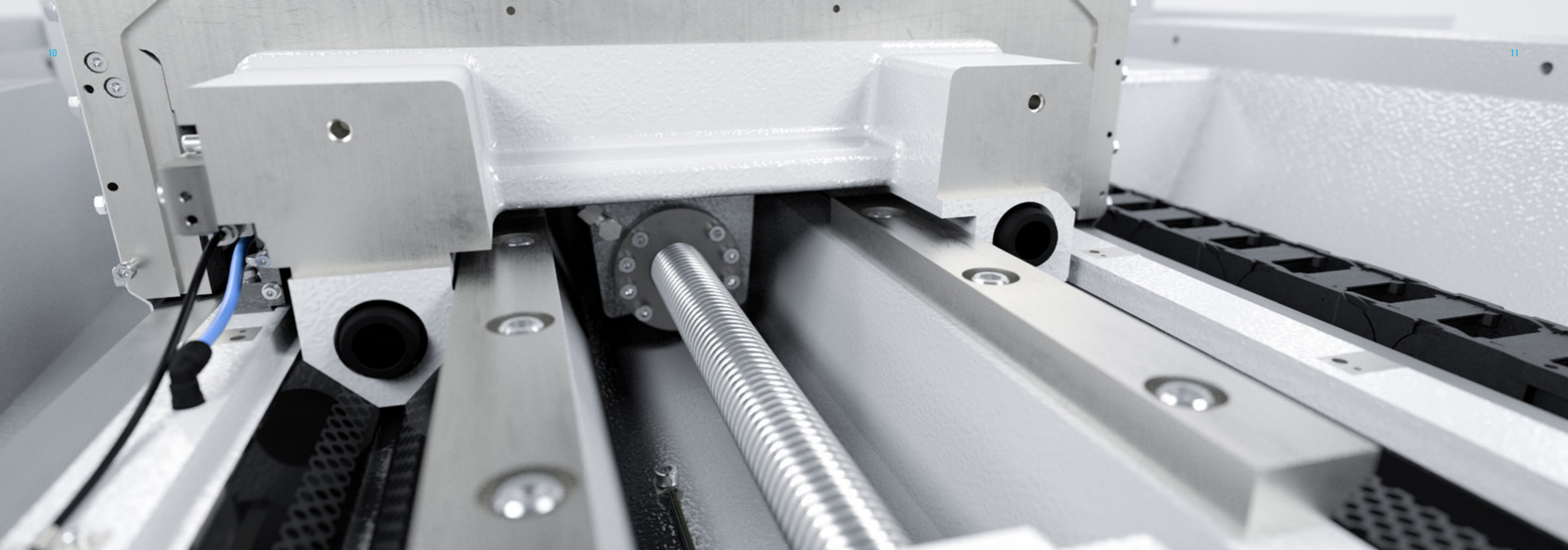

## GRANITAN® S103 MINERAL CASTING MACHINE BASE

The material structure developed by STUDER, which has proved its worth over many years on the basis of the company's own formula, is produced in a facility using the most modern industrial techniques. The excellent damping properties of the machine base ensure that outstanding surface quality is achieved on the ground workpieces. The service life of the grinding wheel is also increased, leading to reduced downtimes. Temporary temperature fluctuations are extensively compensated by the favorable thermal behavior of Granitan®. This results in a high level of dimensional accuracy throughout the day. The StuderGuide® guide system for the longitudinal and cross slides is moulded directly into the machine base and finished with a wear-resistant Granitan® S200 surfacing material. The guideways offer the highest possible accuracy through the entire speed range with high load capacity and dampening levels. Thanks to the robust and maintenance-free design, these excellent guideway properties are hardly subject to wear.

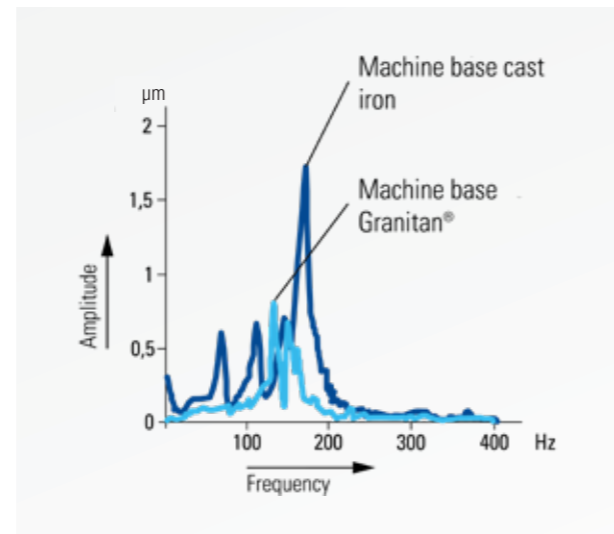

- Vibration-damping
- Thermally stable
- Wear-free

## STUDERGUIDE® IN LONGITUDINAL AND CROSS SLIDES

The longitudinal and cross slides are manufactured from high-quality gray cast iron and have highly precise, ground V and flat guideways. With the distance between the guideways optimally suited to the machine's overall rigidity. The slides rest completely on the guideways of the machine bed through the entire speed range. This is the cornerstone for the excellent straightness e.g., <math>< 0.003\text{ mm}</math> (0.000,12") over 1000 mm (39.4") measured length. The top of the longitudinal slide has a surface that is ground over its entire length and acts as a support for the workhead, the tailstock, as well as accessories and devices. A setup scale, recessed in the table, makes it easy to set up and reset the units on the table. An additional double T-slot enables the optimal utilization of dressing units. The StuderGuide® guide system extends the advantages of hydrostatic systems and guideways with patented surface structure. A huge advantage of StuderGuide® over hydrostatic guideways is the damping component in the movement direction.

The slides are advanced by ball screws connected to a three-phase servomotor via torsion-resistant, bellows-type couplings.

A swiveling table with a swivel angle of +8.5° and fine adjustment is optionally available for the 650 mm (25.6") and 1000 mm (39.4") distances between centers.

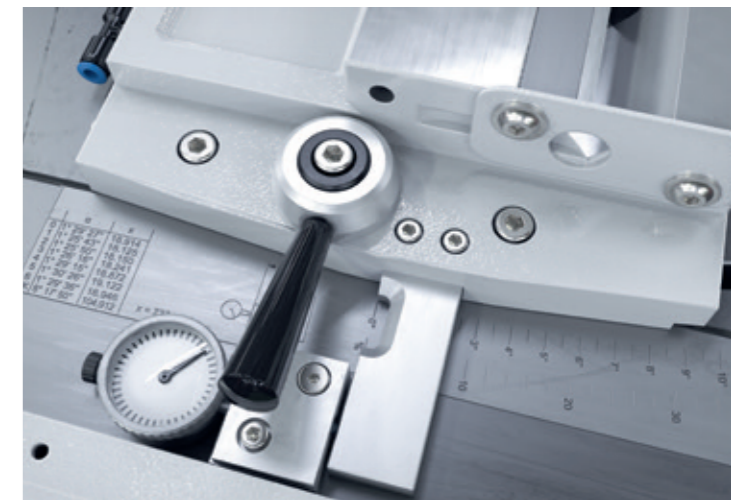

- High geometrical traverse precision
- Auxiliary scale for setup and resetting
- Effective protection of guideways

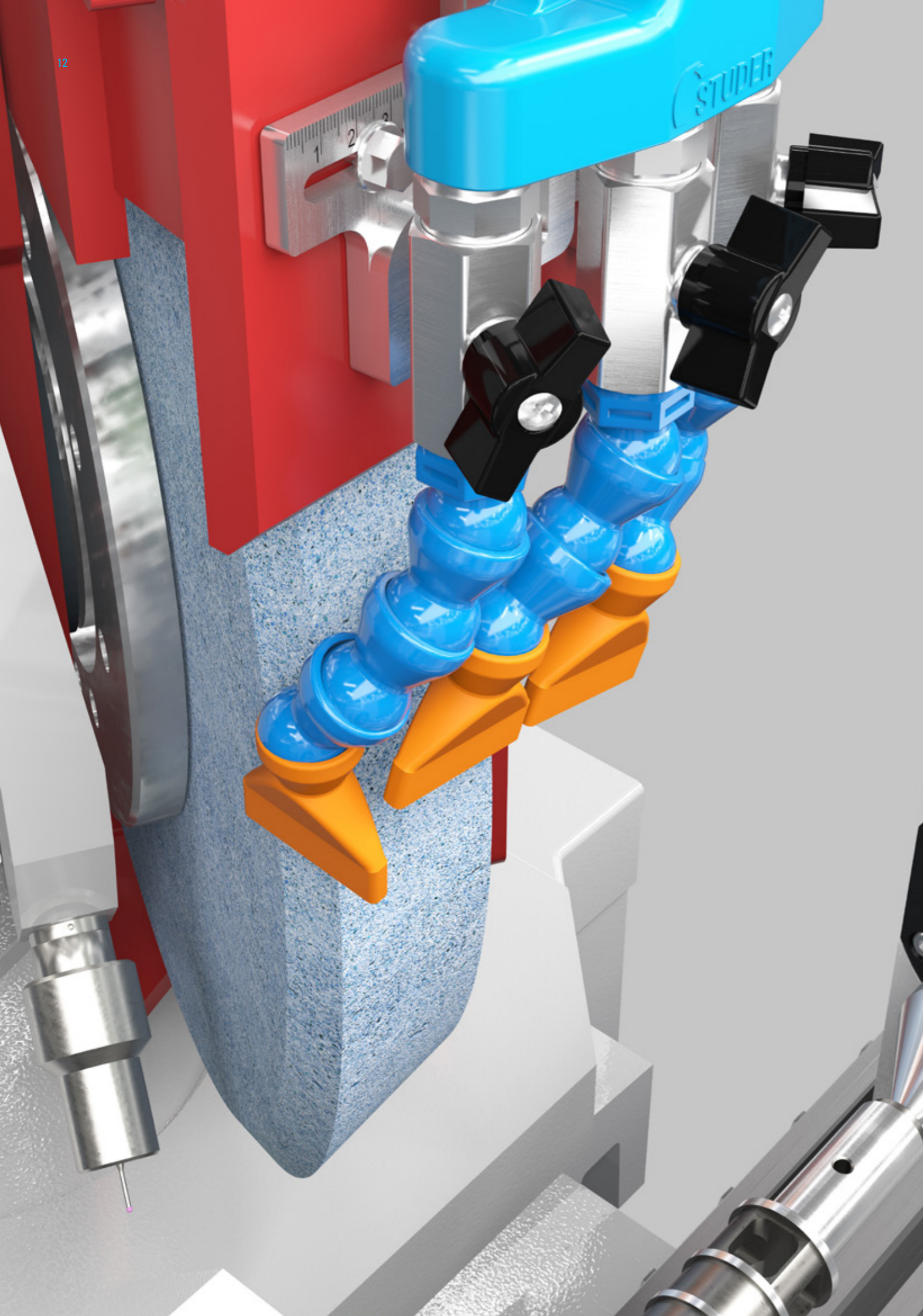

## WHEELHEAD

Two variants are available:

- Universal wheelhead with grinding wheel right or left and an internal grinding attachment. Automatic swiveling with 3° Hirth serration
- External wheelhead with grinding wheel left, 0°, or right, adjustable to 0°/15°/30°

### Grinding wheel size

Diameter 500 mm (20"), width 63 (80 F5) mm / 2.5" (3.15" Form5), bore 203 mm (8"). The max. drive power is 11.5 kW (15.4 hp). The cutting speed of a maximum 50 m/s (9,840 sfpm) enables efficient surface removal rates in the grinding process. The speed of the belt-driven internal grinding spindle is infinitely adjustable. Spindles with maximum speeds of 28,000, 42,000, and 60,000 rpm are available.



- 1 Wheelhead variants
- 2 Internal grinding attachment
- 3 Internal view



- Complete machining
- Cutting speed of up to 50 m/s (9,840 sfpm)
- Internal grinding spindle with continuously adjustable speed

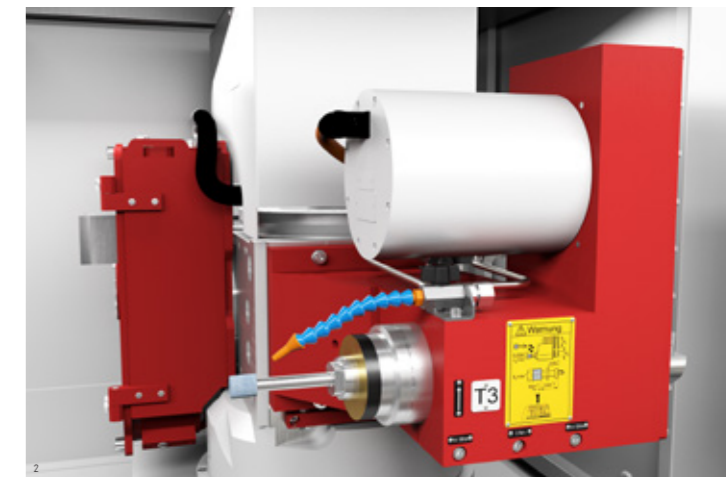

## WORKHEAD

All requirements are covered by wide range of workheads. They are all solidly built in the superior STUDER quality and achieve roundness accuracy of 0.0004 mm (0.000,016") (optionally even 0.0002 mm (0.000,008") in live spindle grinding. Simple cylindricity correction contributes toward perfect live spindle grinding results. Customer-specific workpiece clamping and carrier systems can be easily used.

- High roundness accuracy
- Low-maintenance
- Air lift

### Universal workhead MT4

For external grinding with fixed centers or live spindle grinding; especially suitable for smaller workpieces. The spindle is blocked for grinding between fixed centers. C-axis applications are possible with the indirect measuring system.

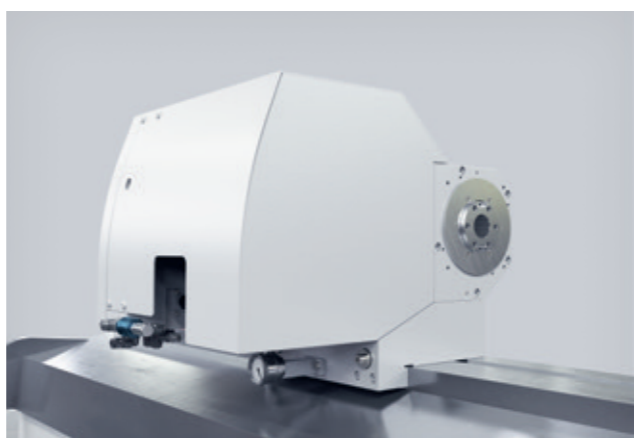

### Universal workhead IS050

For external grinding with fixed centers or for live spindle grinding; suitable for larger/heavier workpieces. The large dia. 50 mm (1.97") spindle bore (bar capacity) is ideal for clamping device attachments. The spindle is blocked for grinding between fixed centers. C-axis applications are possible with the indirect measuring system.

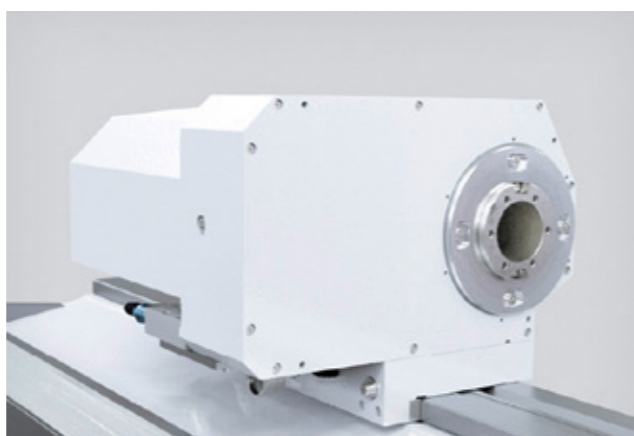

## C AXIS FOR FORM AND THREAD GRINDING

Complete machining also entails form and thread grinding operations to an ever-increasing extent. These processes are made possible by the position and speed-controlled C-axis. The optional C axis is also suitable for thread grinding. With their high dynamic rigidity, the axis drives absorb the acceleration and grinding forces without any problem.

### Form and thread grinding

The favorit offers axis-parallel grinding of fastening threads through to threads of gauge quality. Polygons, excenters, control cams, etc., can be manufactured cost-effectively and to the highest precision.

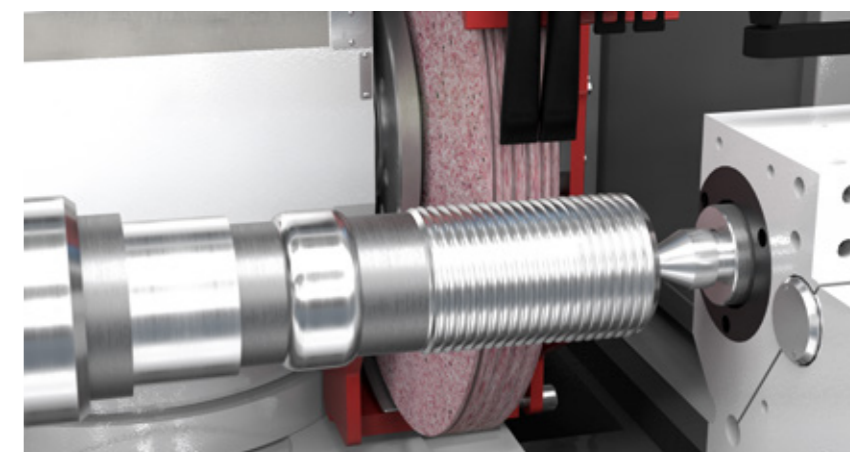



## TAILSTOCK

The generously dimensioned barrel, designed for the use of Morse 3 or 4 taper centers, glides in the tailstock housing. The center pressure can be adjusted with the delicate precision required for grinding high-precision workpieces. The tailstock can be equipped with a hydraulically actuated barrel retraction for workpiece change-over. The fine adjustment enables taper corrections in the range below  $1\ \mu\text{m}$  (0.000,040") when grinding between centers.

### Tailstock MK3

The barrel (dia. 50mm/1.97") is clamped with the help of a spring. The stroke is 35 mm (1.38"). Barrel travel control can be mechanically adjusted. This tailstock is suitable for workpiece weights up to 150kg (330 lbs).

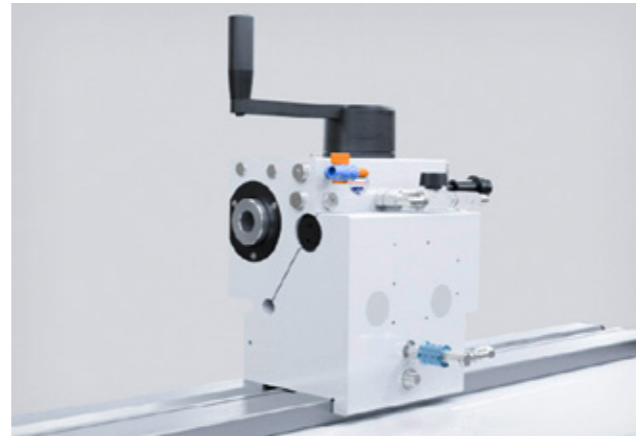

### Tailstock MK4

This tailstock has a larger barrel (dia. 60mm/2.36") and a stroke of 60 mm (2.36"). Clamping takes place with the help of a spring. Barrel travel control can be mechanically adjusted. This tailstock is suitable for workpiece weights up to 150kg (330 lbs).

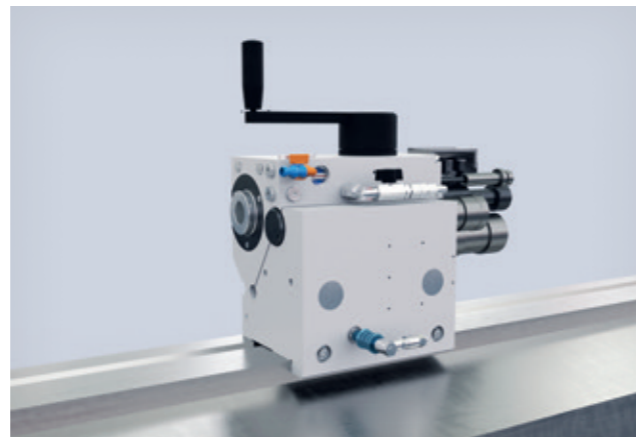

- Low-maintenance
- Air lift
- Option: hydraulic barrel actuation

In order to guarantee optimum thermal stability, the tailstock is flooded with cooling lubricant, as are the barrel and the diamond holder.

## DRESSING

An easy-cutting grinding wheel is essential for cost-effective and high-quality grinding. STUDER offers a large selection of dressing units, in order to coordinate the dressing process flexibly and optimally with the properties specific to the workpiece, tool, or materials. The grinding wheel profile and dressing parameters are easily defined via macros. Another STUDER specialty are the grinding wheel reference points

(T-numbers). This enables programming with nominal dimensions, considerably simplifying the creation of grinding programs.

A software package is available to fine tune the dressing process and includes additional dressing functions.



### Rotary dressing

Rotating dressing tools are particularly suitable for dressing CBN grinding wheels.

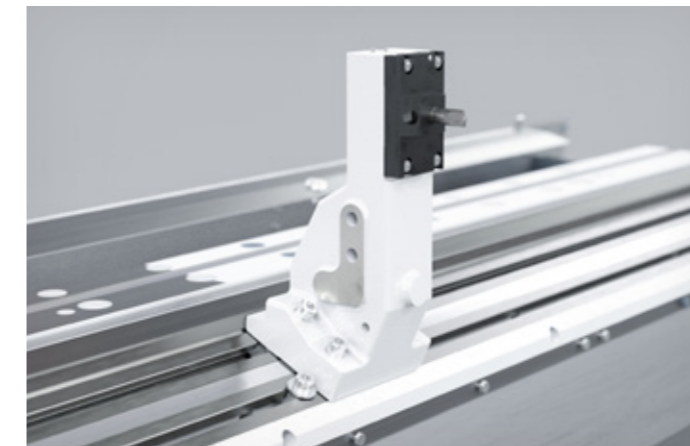

### Fixed diamond holder

The double T-slot allows flexible mounting of the dressing holder along the entire length of the table. The clamping surface is suitable for various dressing tools.

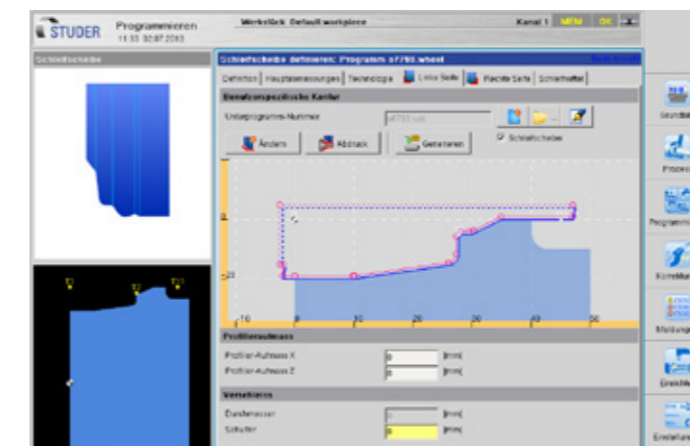

### Grinding wheel profile screen

Easy creation of special grinding wheel shapes from the workpiece geometry.



## CUSTOMER CARE

## CUSTOMER CARE – WE ARE HERE FOR YOU

Our products are designed to meet customer demands for as long as possible, to operate efficiently, reliably, and be available at any time.

From «start up» to «retrofit» – our Customer Care is there for you throughout the working life of your machine. That's why over 200 expert service contacts working around the world in 10 different languages are available locally.

- We provide fast, uncomplicated support.
- We help to increase your productivity.
- We work professionally, reliably, and transparently.
- We provide professional solutions to your problems.

## UNITED GRINDING DIGITAL SOLUTIONS™

We develop solutions to support you in simplifying processes, boosting your machines' efficiency and increasing overall productivity under the «UNITED GRINDING Digital Solutions™» brand.

We are continuously expanding our solution portfolio in the key areas of CONNECTIVITY, USABILITY, MONITORING, and PRODUCTIVITY to make your work in the digital age significantly easier.

Find out more about UNITED GRINDING Digital Solutions™ services on our website in the Customer Care section.



**Start up**  
Commissioning  
Warranty extension



**Qualification**  
Training  
Product support



**Prevention**  
Maintenance  
Inspection



**Service**  
Customer service  
Customer consultation  
HelpLine



**Digital solutions**  
Remote Service  
Service monitor  
Production Monitor

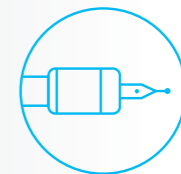

**Material**  
Spare parts  
Replacement parts  
Accessories



**Rebuild**  
Machine overhaul  
Assembly overhaul



**Retrofit**  
Modifications  
Retrofits

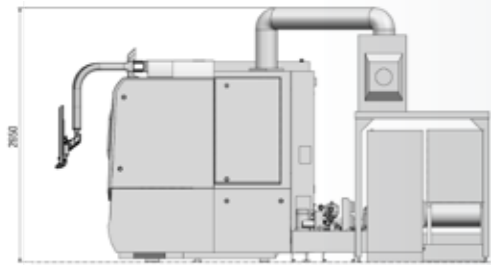
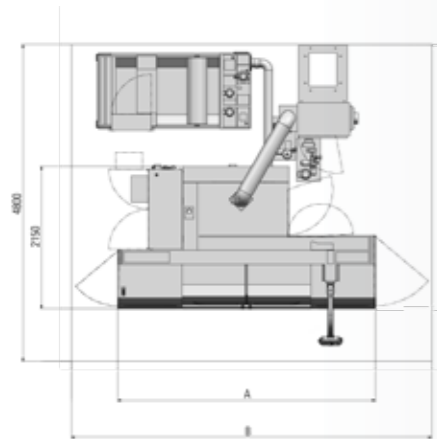

A

B

Center distance 400 mm / (15.7")	2200 mm (86")	4600 mm (181")
Center distance 650 mm / (26")	3200 mm (126")	5100 mm (201")
Center distance 1000 mm / (39.4")	3900 mm (154")	5450 mm (215")
Center distance 1600 mm / (63")	5100 mm (201")	6650 mm (262")

## TOTAL WEIGHT

Center distance 400 mm / (15.7")	7500 kg (16,500 lbs)
Center distance 650 mm / (26")	9000 kg (19,800 lbs)
Center distance 1000 mm / (39.4")	10,000 kg (22,000 lbs)
Center distance 1600 mm / (63")	11,500 kg (25,300 lbs)

The information given is based on the technical levels of our machine at the time of this brochure going to print. We reserve the right to further develop our machines technically and make design modifications. This means that the dimensions, weights, colours, etc. of the machines supplied can differ. The diverse application possibilities of our machines depend on the technical equipment specifically requested by our customers. The equipment specifically agreed with the customer is therefore exclusively definitive for the equipping of the machines, and not any general data, information or illustrations.

## TECHNICAL DATA

### MAIN DIMENSIONS

Distance between centers	400 / 650 / 1000 / 1600 mm (15.7"/25.6"/39.4"/63")
Centre height	175 mm (6.9")
Max. workpiece weight between centers	80 / 150 kg (176 / 330 lbs)

### CROSS SLIDE: X AXIS

Max. travel	370 mm (14.5")
Speed	0.001 – 15,000 mm/min (0,004 – 590 inch/min)
Resolution	0.00001 mm (0.4 mill")

### LONGITUDINAL SLIDE: Z AXIS

Max. travel	500 / 800 / 1150 / 1750 mm (19.7 / 31.5 / 45.3 / 68.9 inch)
Speed	0.001 – 20,000 mm/min (0,004 – 788 inch/min)
Resolution	0.00001 mm (0.4 mill")

### GUARANTEED WORKING PRECISION

Surface straightness	
Measuring length 400 mm (15.7")	0.0020 mm (0.000,080")
Measuring length 650 mm (25.6")	0.0025 mm (0.000,1")
Measuring length 1000 mm (39.4")	0.0030 mm (0.000,120")
Measuring length 1600 mm (63")	0.0040 mm (0.000,160")

### CONNECTED LOAD

Total connected load	20 kVA
Air pressure	5.5-7 bar (80-101 psi)

### WHEELHEAD

	Type: external	Type: universal
Swivel range	0° / 15° / 30°	-30° to 225°
Automatic swivelling axis		3 deg Hirth
Fitting taper	dia. 73 mm (2.87")	dia. 73 mm (2.87")
Driving power	max. 11.5 kW (15.4hp)	max. 11.5 kW (15.4hp)
Grinding wheel, dia. x width x bore	500 × 63 (80 F5) × 203 mm (20" × 2.5"(3.15"Form5) × 8")	500 × 63 (80F5) × 203 mm (20" × 2.5"(3.15"Form5) × 8")
Circumferential Speed	up to 50 m / s (9840 sfpm)	up to 50 m / s (9840 sfpm)

#### Internal grinding attachment for pulley spindles

Spindle diameter	dia. 80 mm (3.15")
Speeds	28,000 / 42,000 / 60,000 rpm

### UNIVERSAL WORKHEAD

Speed range	1–1,500 rpm	1–1,500 rpm	1–650 rpm	1–650 min <sup>-1</sup>
Fitting taper	MT4/dia. 70 mm	MT5	MT5/dia. 110 mm (4.33")	ISO50/dia. 110 mm (4.33")
Spindle bore (max.bar feedthrough dia.)	dia. 26 mm (1.02")	dia. 30 mm (1.18")	dia. 38 mm (1.49")	dia. 50 mm (1.97")
Driving power	1.8 kW (2.4hp)	1.8 kW (2.4hp)	2.5 kW (3.35hp)	2.5 kW (3.35hp)
Load for live spindle grinding	70 Nm (52 lbf-ft)	70 Nm (52 lbf-ft)	180 Nm (134 lbf-ft)	180 Nm (134 lbf-ft)
	0.0004 mm (0.000,016")	0.0004 mm (0.000,016")	0.0004 mm (0.000,016")	0.0004 mm (0.000,016")
Roundness accuracy during live spindle grinding	(option: 0.0002 mm / 0.000,008")	(option: 0.0002 mm / 0.000,008")	(option: 0.0002 mm / 0.000,008")	(option: 0.0002 mm / 0.000,008")
C axis standard, indirect measuring system	0,0001°	0,0001°	0,0001°	0,0001°

### TAILSTOCK

Fitting taper	MT3/MT4	MT4
Travel of barrel	35 mm (1.38")	60 mm (2.36")
Diameter of barrel	50 mm (1.97")	60 mm (2.36")
Fine adjustment for cylindricity corrections	±40 µm (±0.0016")	±80 µm (±0.0032")

### CONTROL UNIT

Fanuc 0i-TF

## FRITZ STUDER AG

The name STUDER stands for more than 110 years of experience in the development and production of precision cylindrical grinding machines. "The Art of Grinding." is our passion, highest precision is our aim and top Swiss quality is our benchmark.

Our product line includes both standard machines, as well as complex system solutions in high-precision cylindrical grinding for machining small and medium-sized workpieces. In addition, we offer software, system integration, and a wide range of services. As well as receiving a complete tailor-made solution, the customer also benefits from over 110 years of know-how about the grinding process.

Our customers include companies from the machine tool industry, automotive, tool and die makers, the aerospace industry, pneumatics/hydraulics, electronics/electrical engineering, medical technology, the watch industry, and job shops. They value maximum precision, safety, productivity, and longevity. As one of the market and technology leaders in universal, external, internal cylindrical, and contour grinding, with 25,000 systems delivered, STUDER has stood for precision, quality, and durability for decades. STUDER's products and services include hardware, software, and a wide range of services in the pre-sales and after-sales sector.



## UNITED GRINDING GROUP

UNITED GRINDING Group is one of the world's leading manufacturers of grinding, eroding, laser, and measuring machines, as well as machine tools for additive manufacturing. With roughly 2.300 employees at more than 20 manufacturing, service, and sales locations, the group is organized in a customer-oriented and efficient way.

Through its MÄGERLE, BLOHM, JUNG, STUDER, SCHAUDT, MIKROSA, WALTER, EWAG, and IRPD brands, as well as competence centers in America and Asia, UNITED GRINDING offers broad application expertise, a large product portfolio, and a full range of services for the production of high-precision components.

«We want to make our customers even more successful – UNITED FOR YOUR SUCCESS»

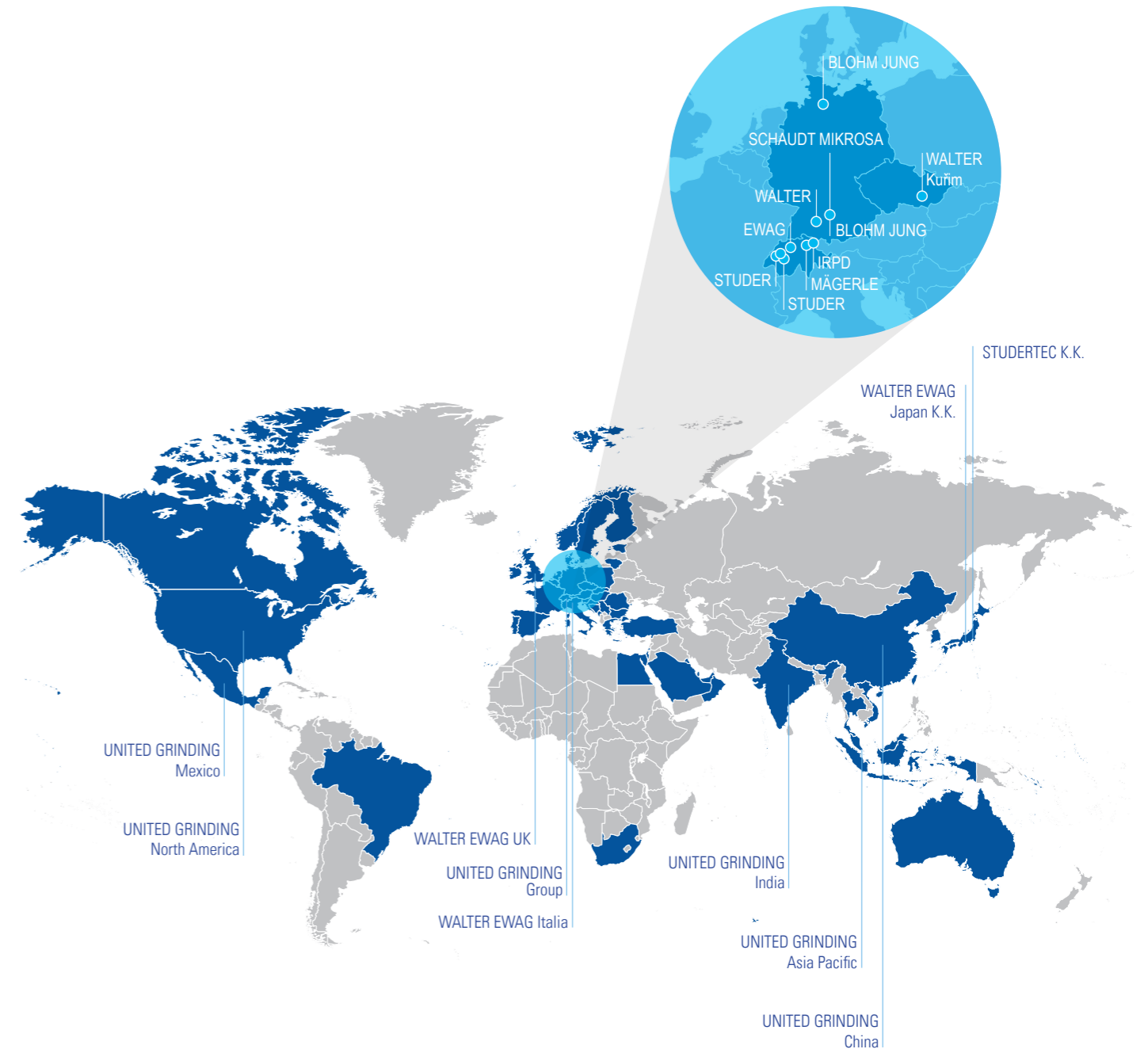



Fritz Studer AG  
3602 Thun  
Switzerland  
Phone +41 33 439 11 11  
info@studer.com  
studer.com



**ISO 9001**  
**VDA6.4**  
certified

