

MC7

GRINDING CENTER FOR EFFICIENT
MACHINING OF COMPLEX WORKPIECES



A member of UNITED MACHINING SOLUTIONS

MC7

DIMENSIONS

- X-axis (longitudinal stroke): 700 mm
- Y-axis (vertical stroke): 650 mm
- Z-axis (transverse stroke): 570 mm

HARDWARE

- Modular machine concept
- P360 coolant nozzle technology
- Grinding wheel size up to 500 mm
- 72-position tool changer for tools and grinding wheels up to Ø 400 mm
- Spindle power: 30/62 kW
- Spindle speeds up to 12,000 rpm
- 5-axis system
- Grinding, milling and drilling capability
- Table and overhead dressing solutions
- C.O.R.E. panel

SOFTWARE

- Pre-programmed grinding and dressing cycles
- Intuitive operation
- Focus on work and production safety
- CAD/CAM connection
- C.O.R.E. operating system

« With P360, one clamping is all it takes: The MC7 performs grinding, milling and drilling at 12,000 rpm – unlocking new levels of efficiency in complex machining. »

YOUR BENEFIT

BLOHM designed the MC7 specifically for multi-face machining of complex workpieces in a single clamping. With its high-performance spindle (up to 12,000 rpm) and large working area, it's ideal for turbine vanes and blades in aerospace and energy applications.

The P360 coolant nozzle technology and flexible axis combinations enable grinding of complex geometries. The optional tool changer, continuous dressing process, and multiple coolant supply options ensure high material removal rates with excellent profile accuracy. The machine accepts loading from front, top, and side for full automation.

The MC7's platform concept combines power, precision and flexibility in a compact footprint – your all-in-one solution for advanced profile grinding.

- Reduced setup times through single-clamping multi-face machining
- Optimal grinding results via uncompromising coolant supply
- Shorter processing times by combining different grinding processes
- Additional machining capability with integrated milling and drilling tools
- Process optimization through interchangeable measuring probe
- Production line ready platform for high-efficiency manufacturing
- Digital Solutions integration directly on the machine
- Fast Customer Care support with direct machine interaction

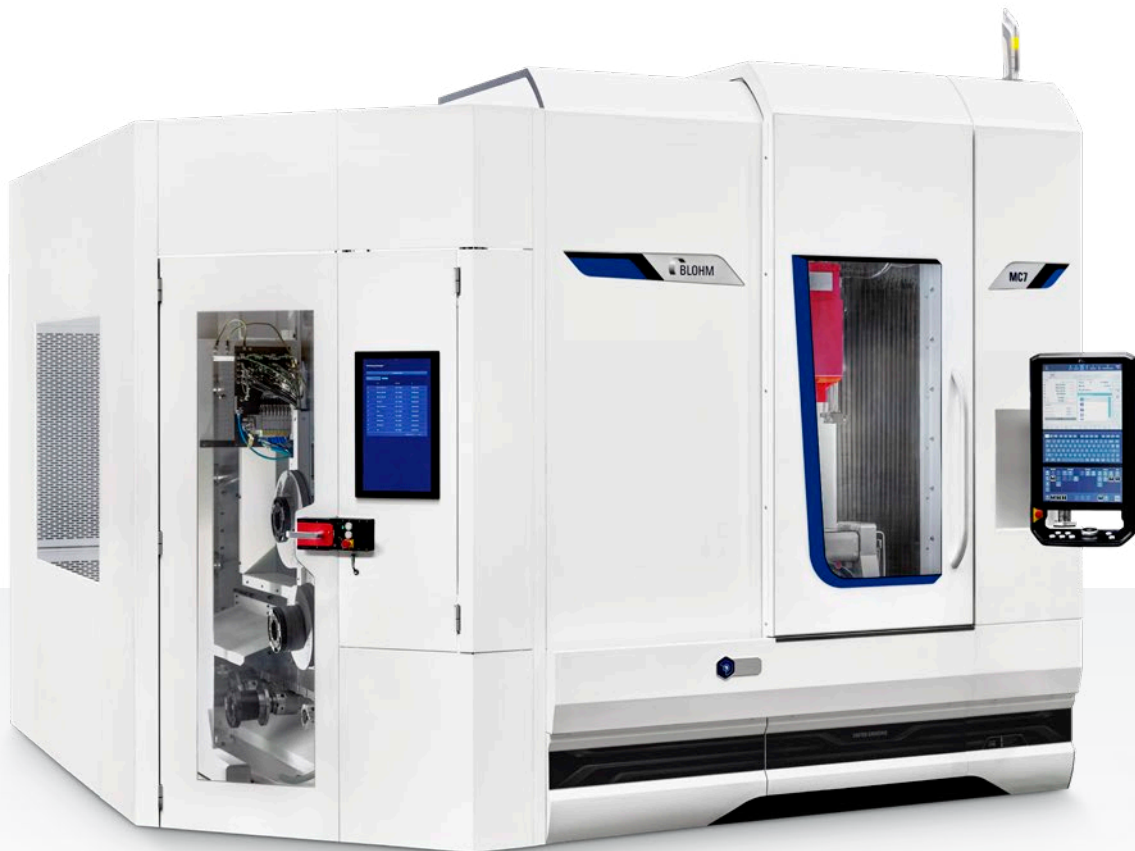

C.O.R.E. – CUSTOMER ORIENTED REVOLUTION

With C.O.R.E., we make your production fit for the digital future.

The C.O.R.E. system from UNITED GRINDING is a future-oriented hardware and software platform that takes the operation, networking and digitalization of machine tools to a new level. C.O.R.E. was developed to make our machines and your production environment fit for the digital industry of tomorrow. Operation is simple and intuitive via the multi-touch display, with a modern and customizable user interface. Thanks to the standard-

ized hardware and software architecture, all UNITED GRINDING machines equipped with C.O.R.E. technology are network-compatible and can be easily integrated into digital factories. All common interface formats are supported. C.O.R.E.'s modern IoT technology core also enables data-based value-added services and integration and communication with cloud-based customer platforms.



C.O.R.E. ARCHITECTURE

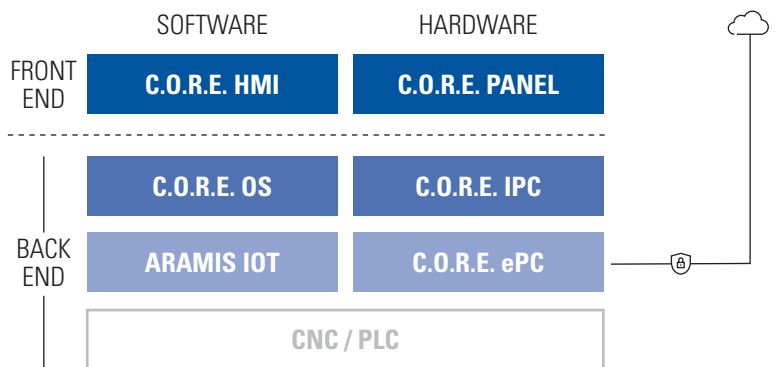

C.O.R.E. PANEL & HMI – NEXT-GENERATION MACHINE OPERATION

Like a large smartphone

With C.O.R.E., UNITED GRINDING has redefined the interaction between man and machine tool. Modern design combined with the most advanced technology to meet the operator requirements of tomorrow. The 24" multi-touch display enables navigation by touch and swipe gestures, similar to a smartphone. The uniform HMI for all UNITED GRINDING machines facilitates set-up, operation and general maintenance. Customizable user roles enable the display and restriction to role-relevant information and thus increase user-friendliness and safety. With the integrated front camera on the panel, assistance can be provided directly at the machine via Remote Service.

Future-proof

The digital capabilities of your machine with C.O.R.E. technology continue to grow. The C.O.R.E. HMI is continuously being expanded with new functionalities, widgets and apps to make it even more user-friendly and customizable. The arrangement, type and size of the tiles on the HMI can be customized so that every machine operator always has the information that is important to him or her at a glance.

In future, new software updates and functionalities will be easy to install via the customer portal, so you will always be up to date.



5.8

Technical data

- 24" Full HD Multitouch-Display
- Override rotary switch with cycle start
- Standardized function keys
- Integrated 2-hand start
- Electronic key system (RFID)
- Integrated front camera
- Tilt adjustment



APPLICATION

APPLICATION EXAMPLES AND MACHINING CAPABILITIES

In aviation and energy sectors, component complexity continues to increase while tolerances become ever tighter. The MC7 grinding center meets these challenges through its unique combination of 5-axis flexibility, multi-process capability, and modular configuration options.

From small aerospace turbine blades to large industrial gas turbine vanes, from shrouded designs to precision-ground root forms – the MC7 handles the full spectrum of turbine components. Beyond turbines, the same platform produces thread rolling dies, mold components, gear wheels, and bearing rings with equal precision.

Turbine



Mold and Die



Various parts



MODULAR PLATFORM CONFIGURED FOR YOUR SUCCESS

The flexible platform concept of the MC7 enables manufacturers of turbines and various other parts to produce them with the optimal machine configuration from the same platform. This allows users to benefit from synergies in operation, maintenance and spare parts management.

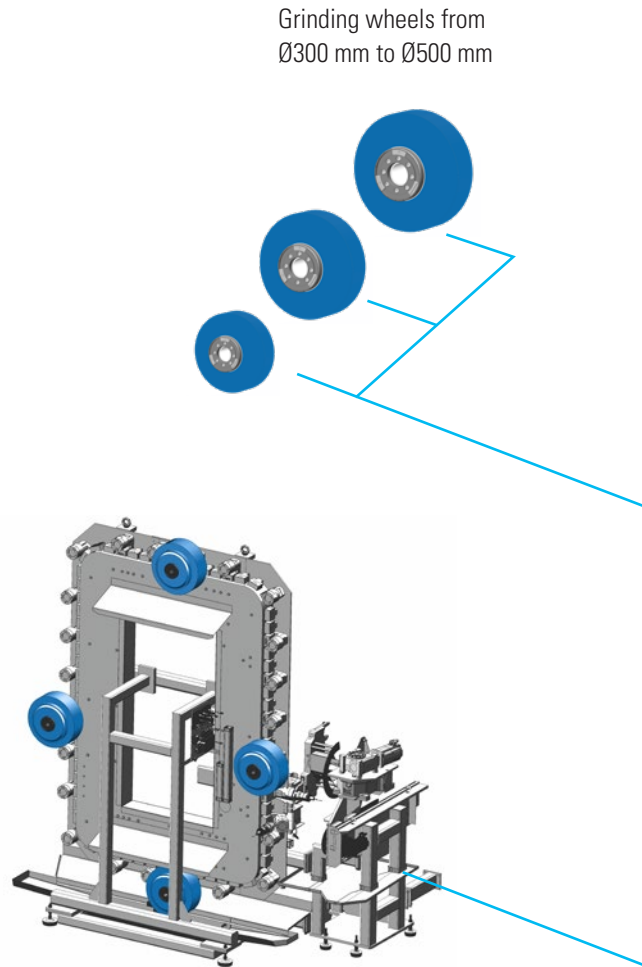

Grinding wheels from
Ø300 mm to Ø500 mm

Tool changer with quick
change system (72 positions)

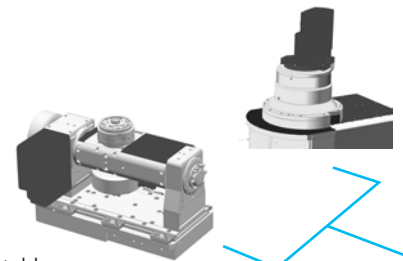

Rotary swivel tables:
A-C axis or B-C axis

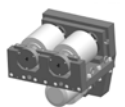
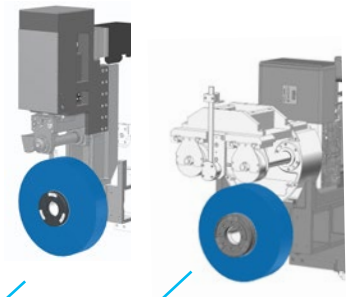

Table dresser: Flexible
dressing solution positioned
on the machine table

- Unified operation across all configurations – one training, multiple applications
- Standardized maintenance procedures reduce downtime and service complexity
- Common spare parts inventory across your entire MC7 fleet
- Proven components ensure reliability regardless of configuration
- Future-proof design allows upgrades and reconfiguration as needs evolve

Overhead dresser: PA-K160 or PA-K220DS
for high material removal rates



Coolant through spindle

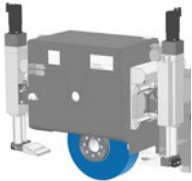
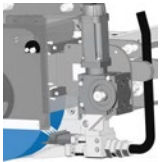
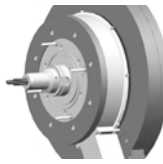

Coolant options: P360 technology,
CNC-controlled nozzles (left/right),
coolant through spindle

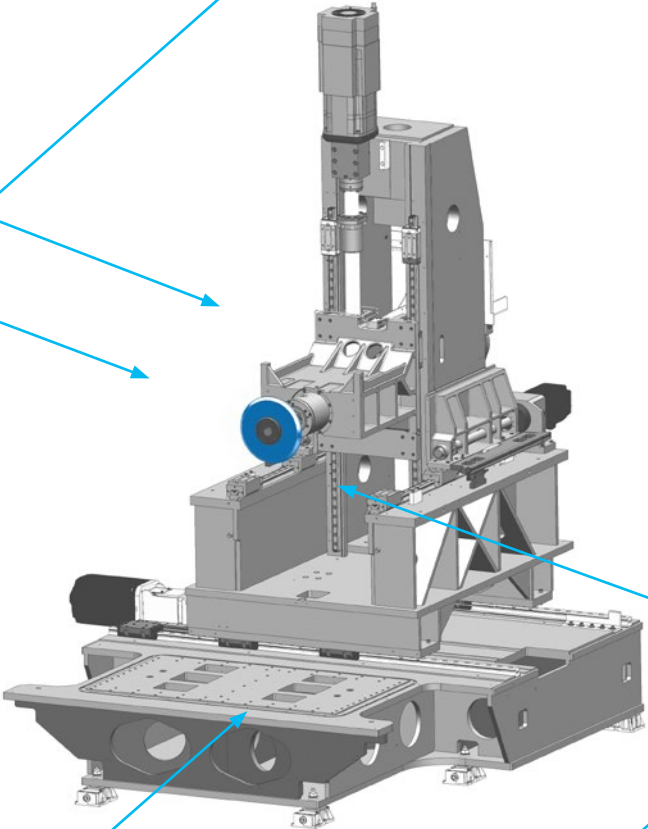

Base frame: Rigid
foundation accommodating
all configuration variants

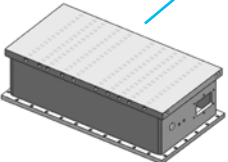

CONFIGURATION 1: A-C AXIS WITH OVERHEAD DRESSING

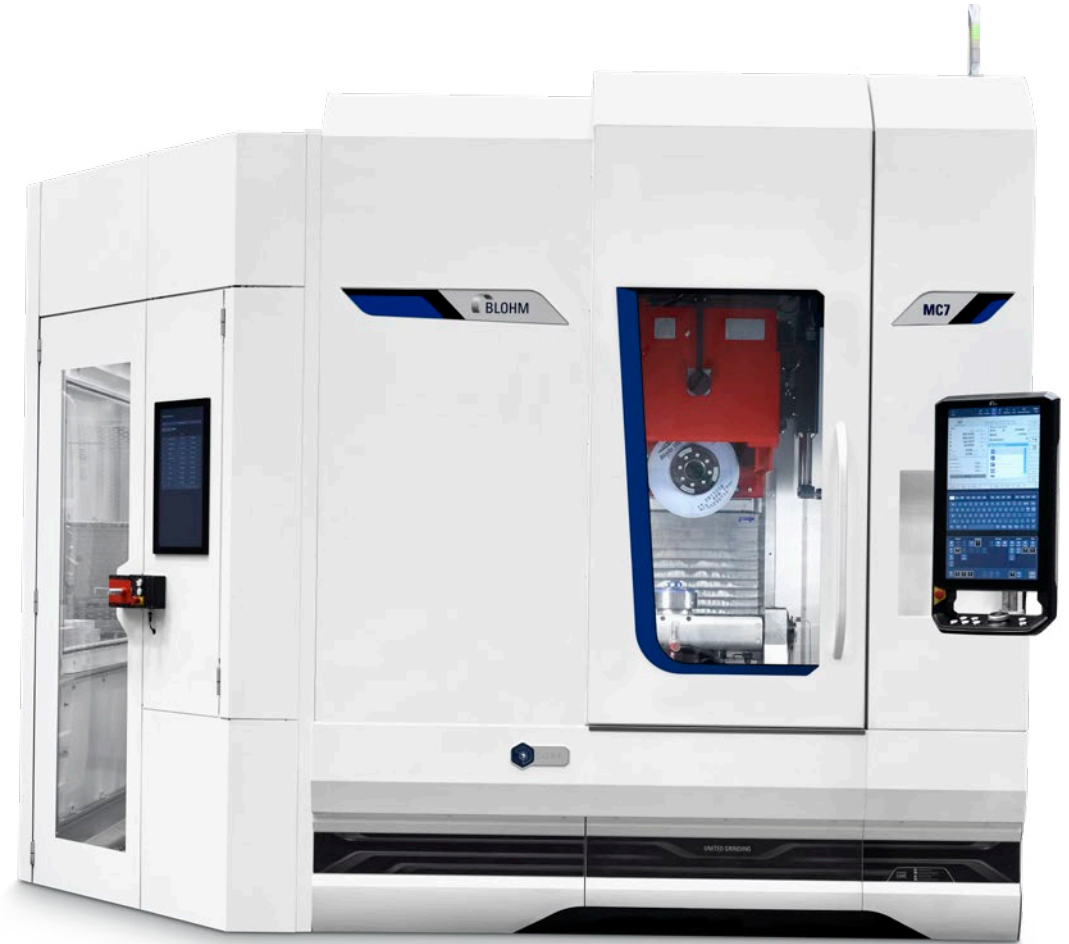

This configuration combines the A-C axis table with overhead dressing technology to excel at manufacturing vanes and shrouds for aerospace and industrial gas turbines. The overhead dresser PA-K220 DS enables aggressive material removal while maintaining exceptional profile accuracy – critical for the complex airfoil geometries of stationary turbine components. The CNC-controlled coolant nozzle positioned on the right (optionally expandable to both sides) ensures optimal cutting conditions throughout the entire grinding process, particularly important when working with heat-resistant superalloys.

CONFIGURATION SPECIFICATIONS

Axis configuration	A-C
Maximum power grinding wheel drive	27.5 kW
Speed Range	1,750 – 8,000 rpm
Tool changer:	
Number pockets	18
Grinding wheel dimensions max. (D x W)	400 x 60 mm
Number of wheels	18
Coolant Nozzle with CNC control	Right
Optional	Left & Right
Overhead dresser, max. roll width	2 x 130 mm

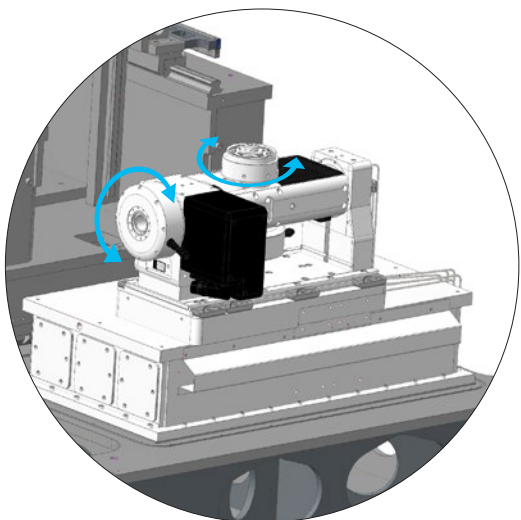
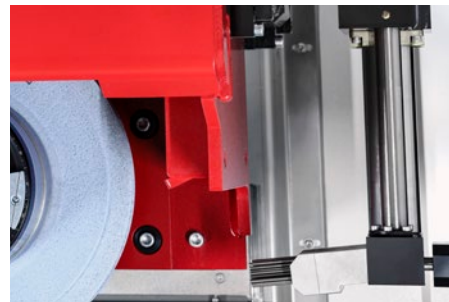
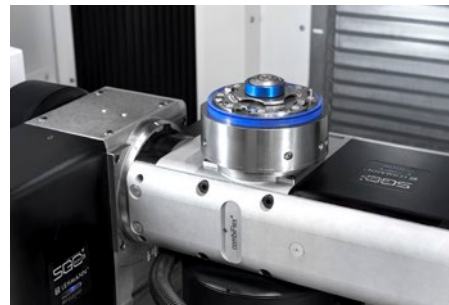

- High output with maximum material removal rates
- Highest productivity through continuous dressing process
- No non-productive time compared to table dresser solutions
- Constant dimensional and form stability throughout production
- Consistent surface quality and controlled grinding temperatures

CONFIGURATION 2: B-C AXIS WITH P360 TECHNOLOGY

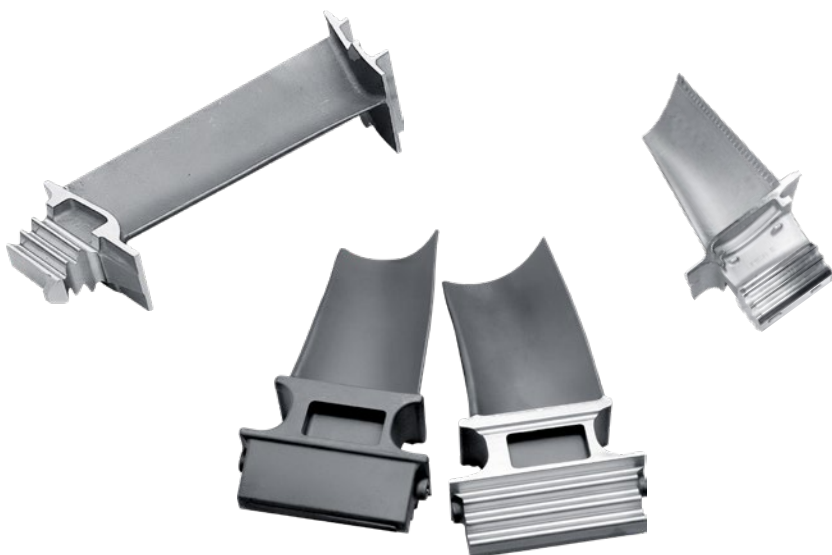

The B-C axis configuration with P360 coolant technology is specifically designed for turbine blades and shrouded blades in aerospace and industrial gas turbine applications. This setup enables complete machining in a single clamping – from root to blade tip. The P360 system features 360-degree movement with two full CNC axes and infinite position control, automatically adjusting coolant delivery to any location on the wheel throughout the grinding process. A table dresser with 300 mm (2x150 mm) capacity accommodates various blade profile requirements.

CONFIGURATION SPECIFICATIONS

Axis configuration	B-C
Maximum power grinding wheel drive	27.5 kW
Speed Range	1,750 – 12,000 rpm
Tool changer:	
Number pockets	24
Grinding wheel dimensions max. (D x W)	300 x 60 mm
Number of wheels	24
P360 standard	12 bar
Optional P360 - 90 degree	50 bar
Table dresser, max. roll width	2 x 150 mm

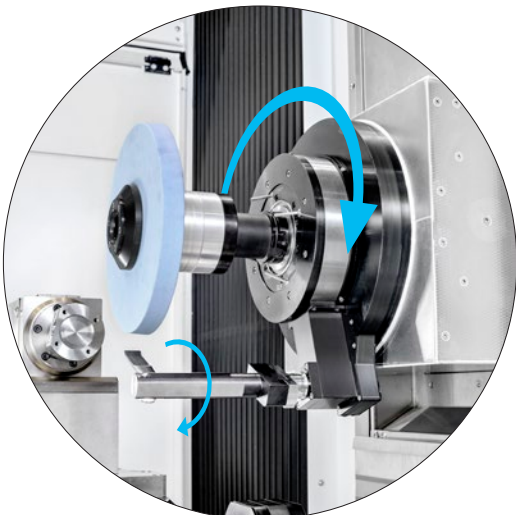
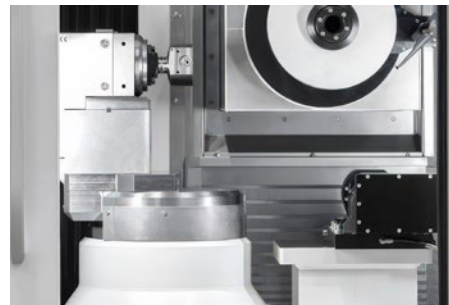

- Multiple operations in one setup
- Complete blade machining without re-clamping ensures highest accuracy
- Precise coolant delivery through P360 technology for consistent surface quality
- Reduced machining times through optimized process integration
- Superior grinding results with optimal cooling at every wheel position

CONFIGURATION 3: A-C AXIS COMPACT DESIGN

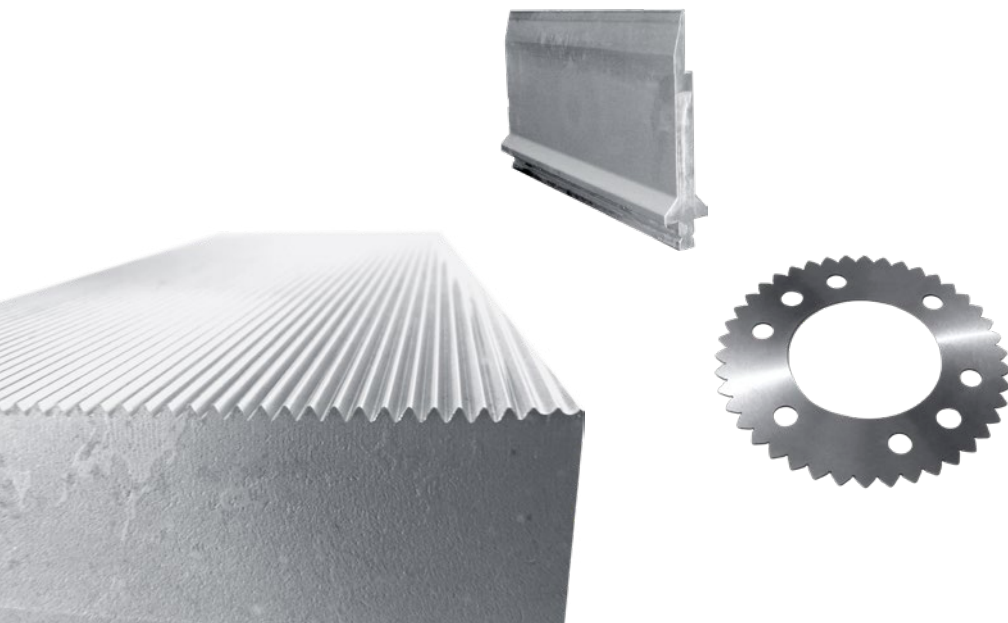

This compact A-C axis configuration is optimized for high-precision manufacturing of thread rolling dies and similar tools across various industries. The streamlined design without tool changer focuses on maximum productivity with large grinding wheels – 500 mm diameter and up to 200 mm width – delivering exceptional material removal rates. The CNC-controlled coolant nozzle on the right side ensures precise cooling during the grinding of complex thread profiles. This configuration combines the proven A-C axis flexibility with a compact footprint, making it ideal for dedicated production lines where quick changeovers and high throughput are essential.

CONFIGURATION SPECIFICATIONS

Axis configuration	A-C
Maximum power grinding wheel drive	27.5 kW
Speed Range	1,750 – 8,000 rpm
Grinding wheel dimensions max. (D x W)	400 x 60 mm 500 x 200 mm
Coolant Nozzle with CNC control	Right
Table dresser, max. roll width	2 x 150 mm
Machine dimensions (W x D x H)	2,350 x 4,425 x 2,690 mm

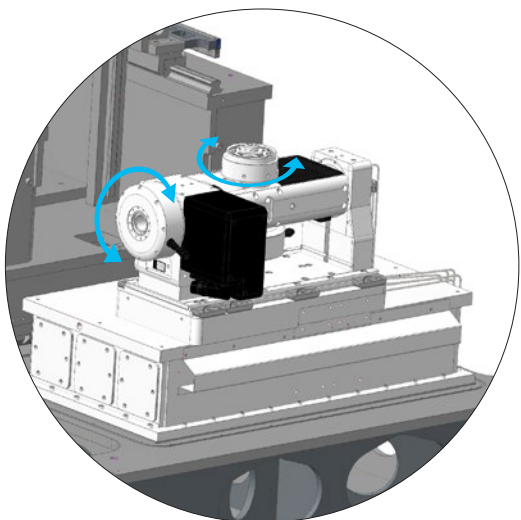
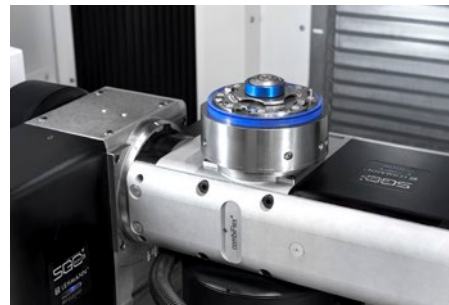

- Compact machine size with low space requirement (2350 x 4425 mm)
- 4-/5-axis configuration for maximum flexibility
- High accuracy and quality grinding results for precision tooling
- Reduced tool costs through optimized wheel utilization
- Simple and easy programming with user-friendly software and predefined grinding cycles

AUTOMATION

Automation and manufacturing cells

The MC7 is prepared for automated loading and unloading in every expansion stage. Flexible and powerful automation solutions are possible with robots and linear systems. Workpiece processing with robot technology is a fast and reliable step towards increasing the degree of utilization, relieving the operator and increasing the productivity of the MC7.

The integration of additional process steps such as cleaning, inspection and measuring is possible. BLOHM's expertise and experience with realised automation solutions guarantee maximum productivity and quality and ensure long term competitiveness.

- ① Tool magazine
- ② Machine MC7
- ③ P360 coolant nozzle
- ④ NC indexing unit
- ⑤ Optional palette system for workpieces
- ⑥ Loading station for tools

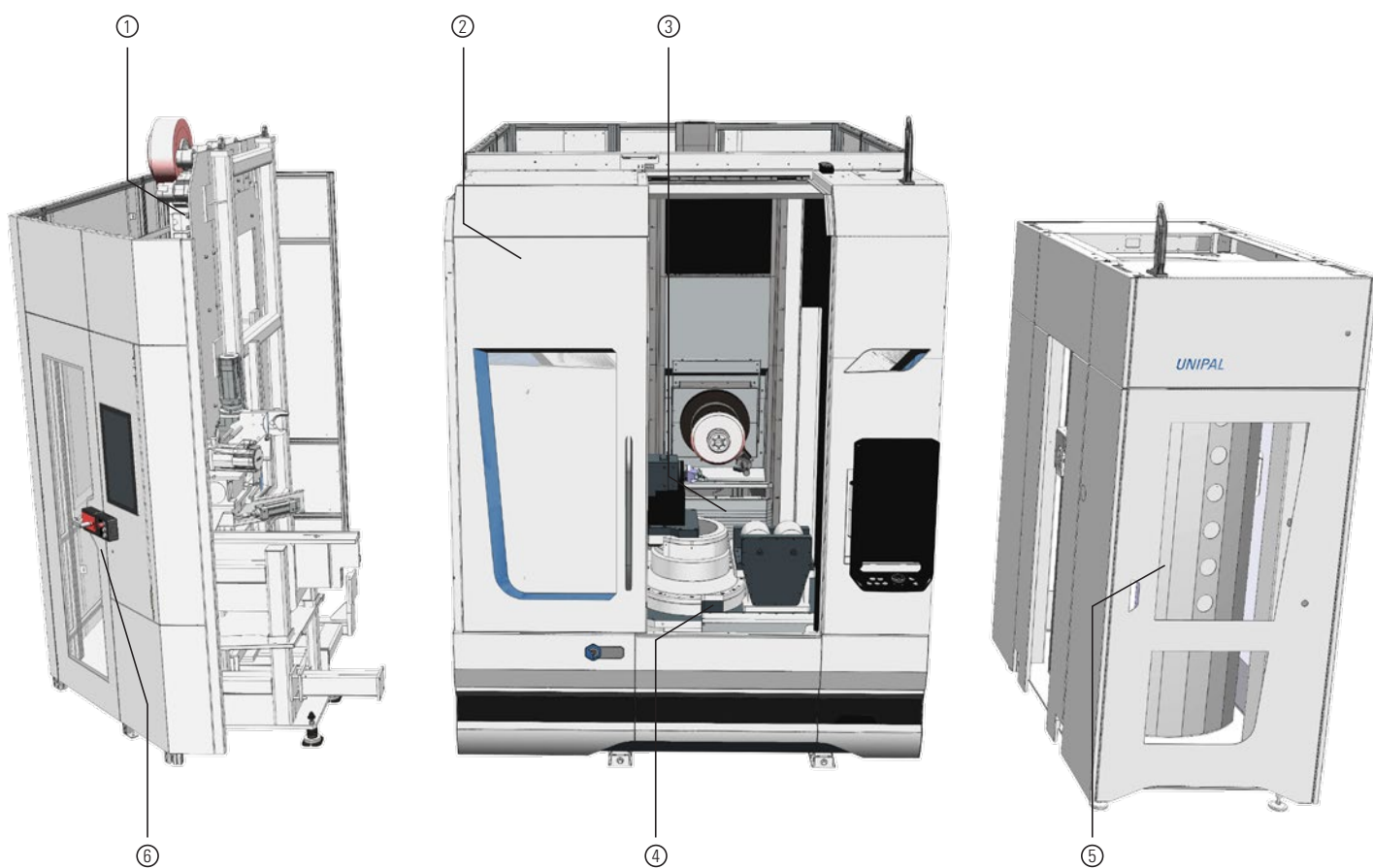

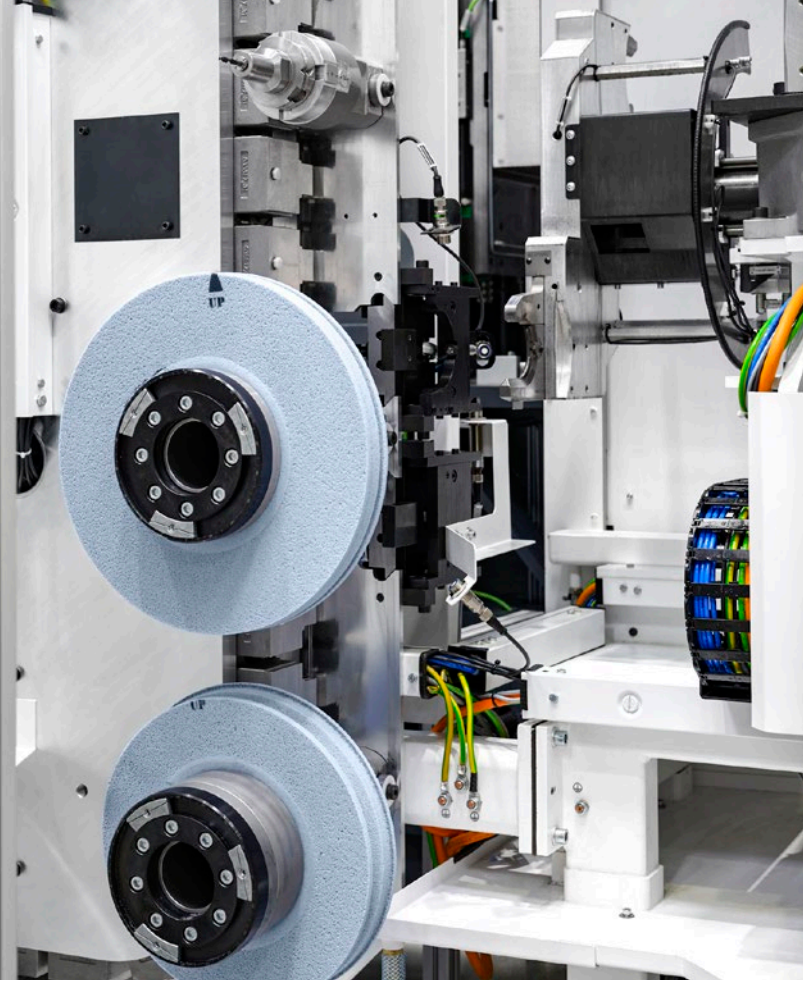

Toolchanger

Optional the MC7 can be equipped with a tool changer. The tool magazine for grinding wheels, milling and drilling tools is designed with 72 positions for tool pockets. All tools are loaded to the magazine safely and ergonomically due to the big access to the loading station.

Change over is carried out in just a few steps and can easily be performed during production. The large tool capacity makes it possible to machine recurring lot sizes without long downtimes. The 72 positions can be flexibly equipped with different variants.

Ergonomic loading and unloading of tools with loading station

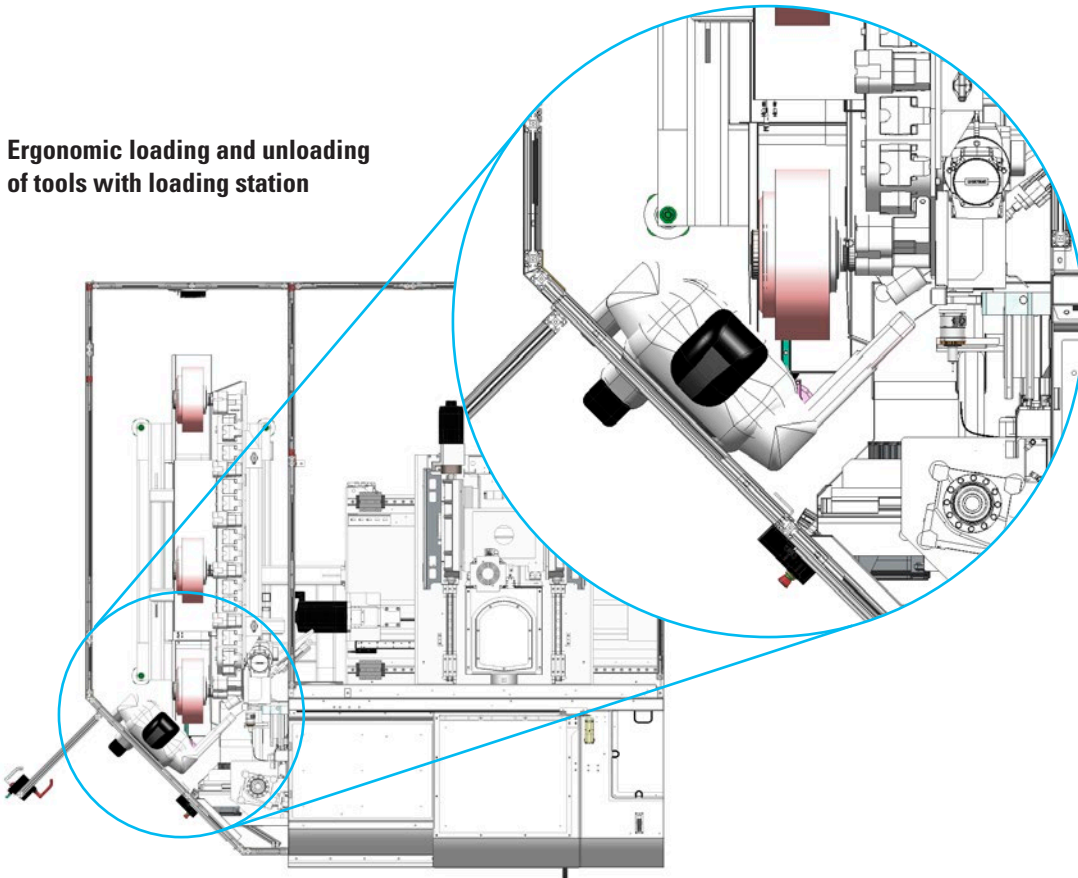

PROGRAMMING

The grinding center is equipped with the SIEMENS SINUMERIK ONE control. Specially visualized and parameterizable grinding and dressing cycles are available for efficient programming of the workpieces. In 5-axis machining, 3D grinding and auxiliary cycles can be programmed for milling and drilling operations.

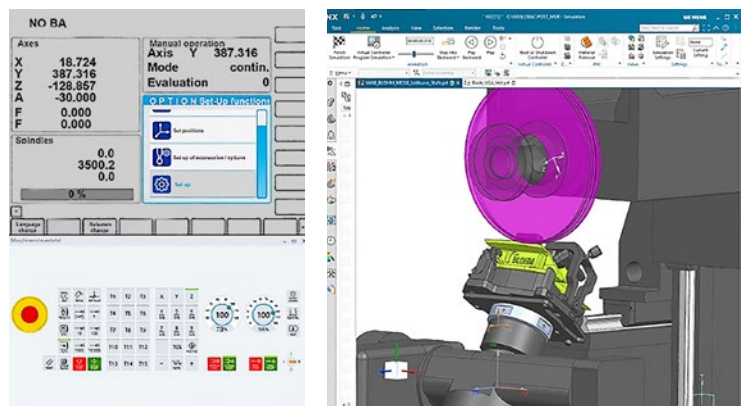

CAD/CAM CONNECTION

A SIEMENS NX postprocessor is available for CAM process development. The generated NC programs take account of the BLOHM grinding cycles. As a result, the programs can be easily edited on the machine control unit via operator guidance.



DIGITAL SUPPORT: ENSURE PRODUCTIVITY, AVOID DOWNTIME

Health monitoring

In C.O.R.E. the load of the axis drive motors are traced and recorded. The data is recorded after assembly of the axes and saved as a fingerprint of the individual axes. Monitoring live data to baseline helps detect small anomalies before failures occur. The HEALTH MONITOR is the tool for predictive maintenance.

Process monitoring

Software tool for tracing of the grinding spindle motor load during grinding. Each individual cut can be viewed. The PROCESS MONITOR allows to set limits with different events like warning light or alarm. Error. The operator has absolute process control and can optimize the process parameters very conveniently. The reject rate can be significantly reduced.

Coolant monitoring

The COOLANT MONITORING is measuring the coolant pressure, flow and temperature. All information can be displayed on the C.O.R.E. panel. The software supports the operator in setting up the coolant parameters and regulates according to the set limits. The operator will run the machine under optimized conditions, deviations generate alarms.



EASE OF OPERATION AND MAINTENANCE

Operation

The machine operates via the swiveling control panel with a view of the working area in the front of the machine. When the splash guard is opened, heavy workpieces including clamping fixture can also be loaded from the top with a gantry or jib crane. Loading from the right side by an automated palette system is an option.

Maintenance

Access for maintenance of the respective units and components of the entire machine is centrally positioned and designed to make maintenance easy. Remote maintenance activities can thus be efficiently performed.



- ① Working area
- ② Splash guard opened at the top
- ③ Automatic side door, closed

- ① Electro cabinet
- ② Central lubrication, fluids and pneumatics



TECHNICAL DATA

MC7

X-axis, Longitudinal stroke	700 mm
Travel speed	0 – 50,000 mm/min
Y-axis, Longitudinal stroke	650 mm
Travel speed	0 – 30,000 mm/min
Z-axis, Longitudinal stroke	570 mm
Travel speed	0 – 50,000 mm/min
Maximum continuous power grinding wheel drive	27.5/62 kW
Rpm range max.	1,750 – 8000/12,000 min ⁻¹
Profile dressing device on table, roll width, max.	2 × 150 mm 1 × 200 mm
Profile dressing device overhead, roll width, max.	2 × 130 mm
Grinding wheel dimensions max. (d x w)	500 × 200 mm
Quick-clamping spindles	HSK-A80
Tool changer positions	72 n/pos
Tool length max.	250 mm
Grinding wheel dimensions (d x t x h)	300 × 60 × 76.2 mm 400 × 60 × 127.5 mm
Measuring system with measuring probe (optional)	

Technical specifications subject to change

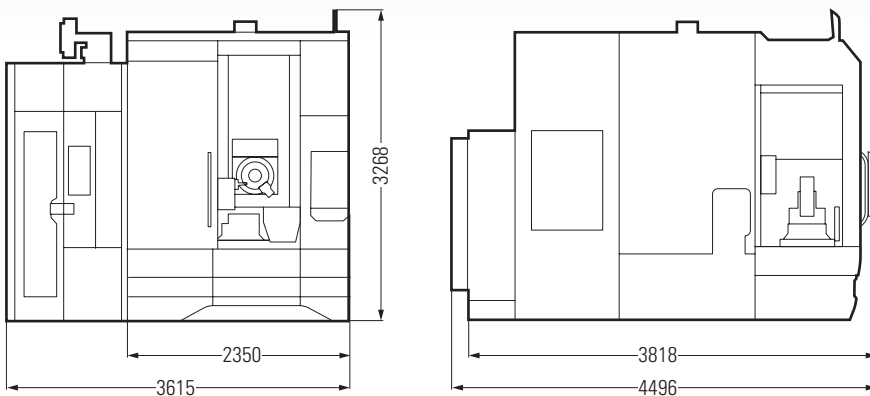

MC7

Dimensions in mm. Options, accessories, or doors in the open position may increase the dimensions of the machine. Subject to change without notice due to technical progress and errors excepted. Information provided without guarantee.

WE ARE HERE FOR YOU!

Our products are designed to meet customer demands for as long as possible, they are intended to operate efficiently, reliably, and be available at any time.

From “Start up” through to “Retrofit” – our Customer Care is there for you throughout the working life of your machine. For this reason, you can rely on competent HelpLines worldwide and Service Engineers near you:

- We will provide you with fast, straight-forward support.
- We will help to increase your productivity.
- We work professionally, reliably and transparently.
- We will provide a professional solution to your problems.



Start up

Commissioning
Extension of the guarantee



Qualification

Training
Product support



Prevention

Maintenance
Inspection



Service

Customer service
Customer advice
Helpline



Digital Solutions

Remote Service

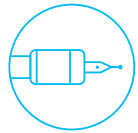

Material

Spare parts
Replacement parts
Accessories



Rebuild

Machine overhauling
Refurbishing of assemblies



Retrofit

Conversions
Retrofitting parts

DIGITAL SOLUTIONS

Digital Solutions stand for products and services that open up the data space of your machine through IoT-based networking, enable seamless integration across the entire store floor in digital value-added networks and provide data-based value-added services and

digital services – for greater efficiency, productivity and competitiveness. You can find out more about the services of Digital Solutions on our website under the Customer Care section.

CUSTOMER CARE

BLOHM JUNG

BLOHM JUNG GMBH

Productivity, performance, and precision—these are the three characteristics that users worldwide associate with flat and profile grinding machines from BLOHM and JUNG. For decades, our machines have been successfully used in a wide variety of applications and under a wide range of conditions. The experience gained from more than 35,000 machines delivered is continuously incorporated into innovations and further developments – with the aim of sustainably increasing our customers’ production efficiency.

Our portfolio ranges from surface grinding machines and universal solutions to customer-specific production machines. Our service and techno-

logy specialists accompany our customers throughout the entire life cycle of the machines – from grinding trials and training to maintenance contracts and retrofit projects. Personal, fast, and competent.

In 2008, the two established brands BLOHM and JUNG were merged under the umbrella of Blohm Jung GmbH. Since then, this combined expertise has set new standards in precision, quality, and cost-effectiveness. As part of UNITED MACHINING SOLUTIONS and with a global sales and service network, Blohm Jung GmbH supports its customers worldwide – and is always close at hand.



ABOUT US

UNITED MACHINING SOLUTIONS

UNITED MACHINING SOLUTIONS is one of the largest machine tool manufacturers in the world. With around 5,000 employees at over 50 global production, service and sales locations, UNITED MACHINING SOLUTIONS is close to its customers and highly efficient. The group is organized into two divisions: UNITED GRINDING and UNITED MACHINING.

UNITED GRINDING includes the brands MÄGERLE, BLOHM, JUNG, STUDER, SCHAUDT, MIKROSA, WALTER, EWAG and IRPD. Its technologies include surface and profile grinding machines, cylindrical grinding machines, machines for tool machining and machine tools for additive manufacturing.

The UNITED MACHINING division includes the brands AGIE CHARMILLES, CHARMILLES, MIKRON MILL, LIECHTI, STEP TEC and SYSTEM 3R. It includes machines for EDM (Electrical Discharge Machining), high-speed milling and laser technology as well as spindle production and automation solutions.

“We want to make our customers even more successful”

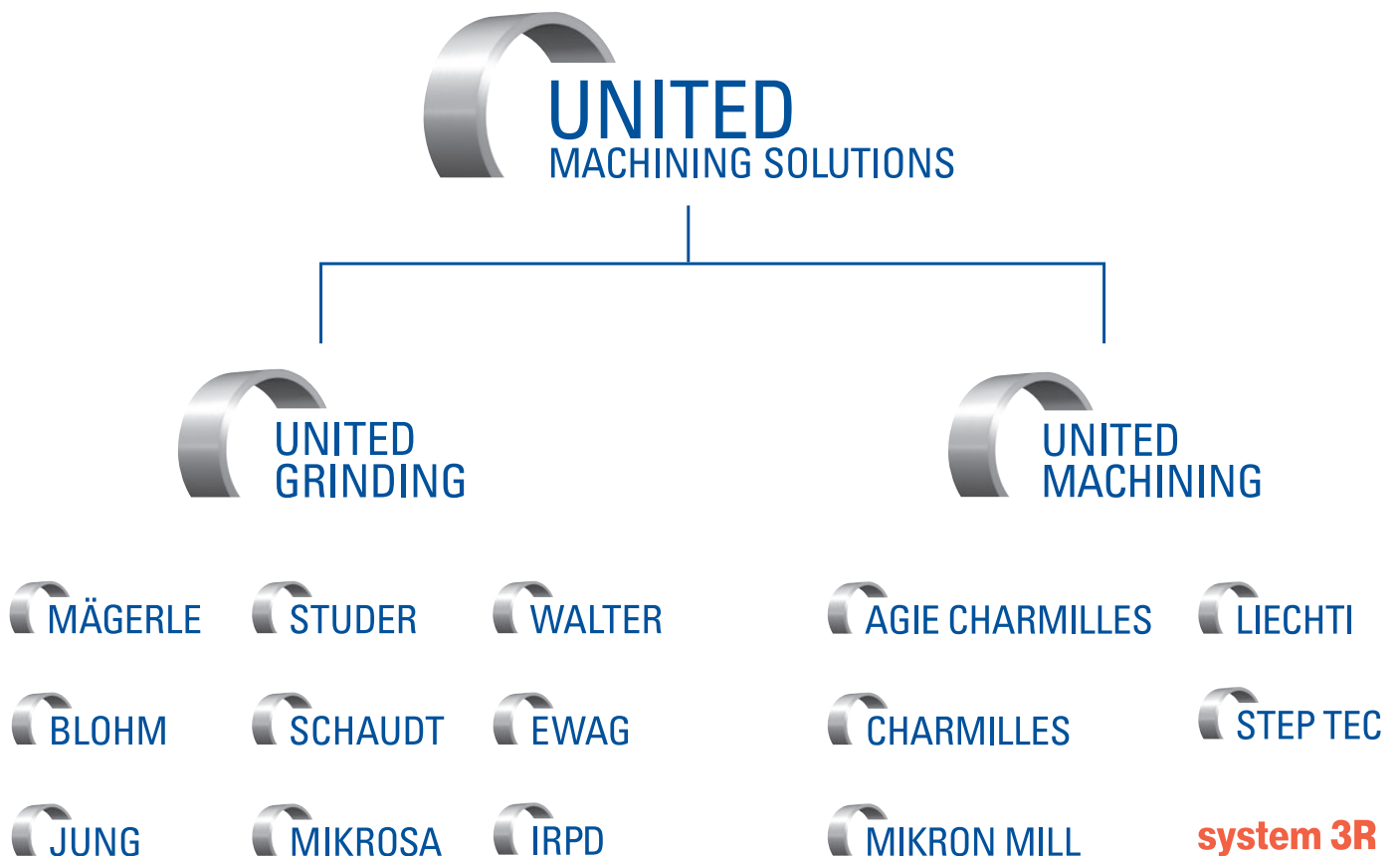



Blohm Jung GmbH

Location Hamburg
Kurt-A.-Körper-Chaussee 63-71 21033 Hamburg, Germany
Phone +49 40 33461 2000
sales-hh@blohmjung.com

Location Göppingen
Jahnstraße 80-82 73037 Göppingen, Germany
Phone +49 7161 612 0
sales-gp@blohmjung.com

Please find worldwide contact information on
blohmjung.com

